

# TraceNet™ ECM-P / FAK-1 Kit

## ECM Electronic Control Module Mounted on FAK-1 Bulkhead Entry

### INSTALLATION PROCEDURES

For Use With TubeTrace™ Bundles

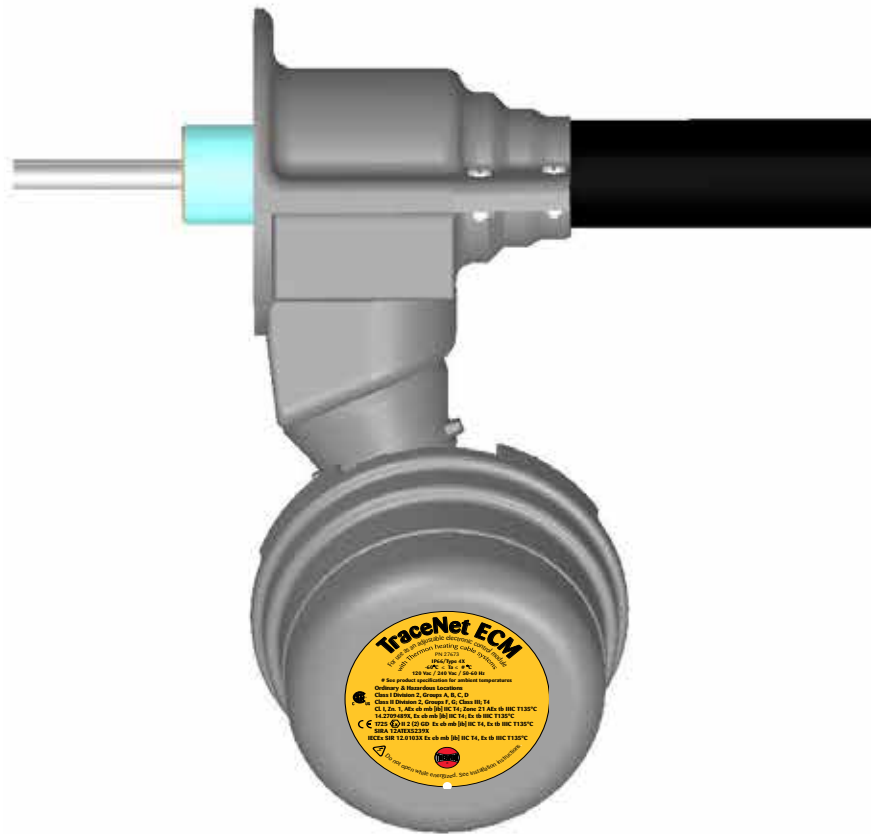

**The Heat Tracing Specialists®**

# TraceNet™ ECM / FAK-1

The following installation procedures are suggested guidelines for the installation of the Terminator ECM/ FAK-1 Split Bulkhead Entry Kit with the ECM Electronic Controller. For translations other than English and local language translation provided here, please contact Thermon. The English language installation procedure shall govern.

## TraceNet ECM / FAK-1 Kit Contents . . .

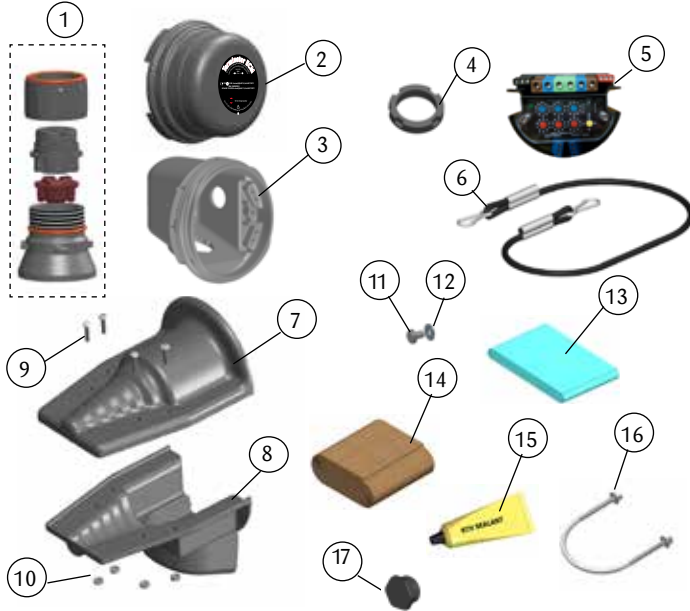

Item	Qty	Description
1	1	Expediter Assembly: Wall Mount Base, Grommet, Grommet Compressor, and Support Cap with O-Ring
2	1	Junction Box Lid
3	1	Junction Box Base with O-Ring & M25 Dust Cap
4	1	Expediter Nut Assembly
5	5	Electronic Control Module w/ Terminal Blocks (Refer to terminal specifications for maximum allowable wire size) ECM Type C - Controller L - Limiter CL - Controller/Limiter
6	1	Junction Box Cord
7	1	Bulkhead Entry Cover (Top)
8	1	Bulkhead Entry Base (Bottom)
9	4	Pan Head S.S. Screws, #10-32 x 19mm
10	4	KEPT S.S. Nuts, #10-32
11	3	M5 Screw
12	3	M5 Lock Washer
13	1	Heat Reflective Tape
14	1	Glass Fiber Tape
15	3	RTV Sealant Tube
16	1	U-Bolt, Washers and Nuts
17	3	Blind Plug

## INSTALLATION PROCEDURES

### Order Separately . . .

#### PETK Power and End Termination Kits (per cable)

PETK-1 for RSX, VSX, BSX

PETK-2 for KSX, HTSX

PETK-3-ECM for HPT, FP

#### RTD Sensors



PT-100-3L  
RTD Control Sensor



PT-100-3L  
RTD Limiter Sensor

### Receiving, Storing and Handling . . .

1. Inspect materials for damage incurred during shipping.
2. Report damages to the carrier for settlement.
3. Identify parts against the packing list to ensure the proper type and quantity has been received.
4. Store in a dry location.

### Manuals . . .

- For operating and monitoring please refer to ECM operating manual.

### Dimensions . . .

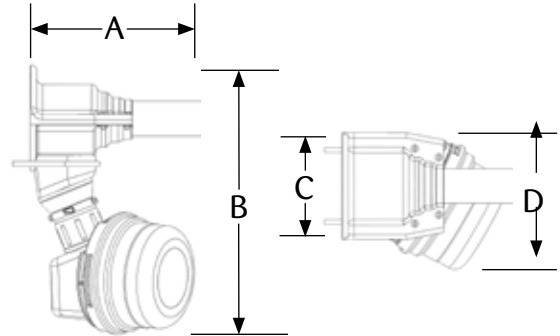

	A	B	C	D
	inch (mm)	inch (mm)	inch (mm)	inch (mm)
TraceNet ECM / FAK-1	(206mm)	(340mm)	(133mm)	(171mm)

### Tools Required . . .



The Heat Tracing Specialists®

# TraceNet™ ECM / FAK-1

The TraceNet ECM / FAK-1 Split Bulkhead Entry Kit is designed to provide accurate control with ECM Electronic Control and make a waterproof seal over the end of TubeTrace and terminate Thermon electric heat trace in an approved Terminator junction box. Review Instructions prior to installation. Kit will make one connection.

## Terminator ECM Certifications/Approvals . . .



II 2 G Ex e mb [ib]Ib IIC T4 Gb SIRA 12ATEX5239X  
II 2 D Ex tb IIIC T135°C IP66 Db



International Electrotechnical Commission  
IEC Certification Scheme for Explosive Atmospheres  
SIR 12.0103X

# INSTALLATION PROCEDURES

## Installation Precautions . . .

- Keep ends of bundles, heat tracing and kit components dry before and during installation.
- To minimize the potential for arcing on electrical heat tracing caused by product damage or improper installation, use appropriate ground-fault circuit protection.
- Installation must comply with Thermon requirements and be installed in accordance with any applicable national and local codes.
- Component approvals and performance ratings are based on the use of Thermon specified parts only. User supplied power connection fittings must be listed or certified for intended use.
- De-energize all power sources before opening enclosure.
- Individuals installing these products are responsible for complying with all applicable safety and health guidelines. Proper personal protective equipment, or PPE, should be utilized during installation. Contact Thermon if you have any additional questions.

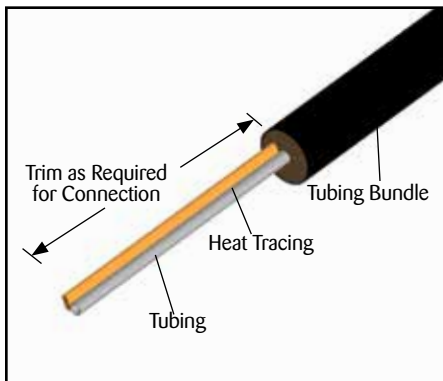

- 1.** Remove outer jacket and insulation from tubing bundle to expose the electric heat trace and tubing. Ensure sufficient heat trace is available for electrical connection. See instructions included with heat trace PETK kit.

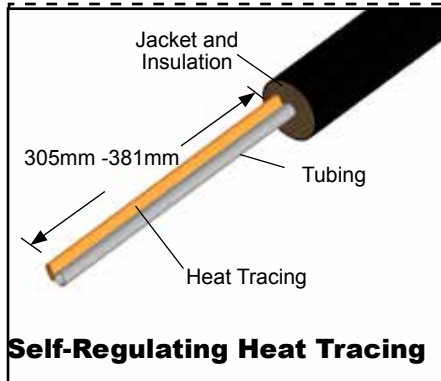

### Self-Regulating Heat Tracing

- 2.** Trim heat tracing to within 305mm - 381mm of the end of the insulation. If self-regulating heat trace proceed to step 3. For Zone-type heat trace continue with identification of bus connection on step 2a.

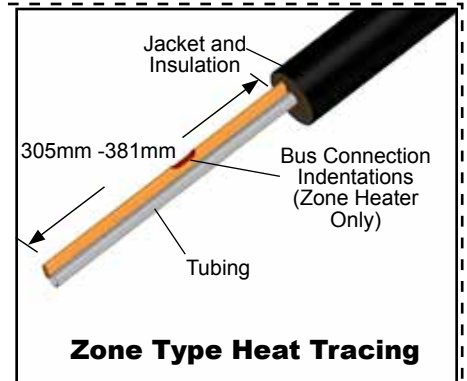

### Zone Type Heat Tracing

- 2a.** Strip back bundle insulation 38mm to 76mm beyond bus connection heat tracing. If bus connection indentation is less than 305mm - 381mm from end of the heat tracing, proceed stripping the bundle insulation to the next indentation.

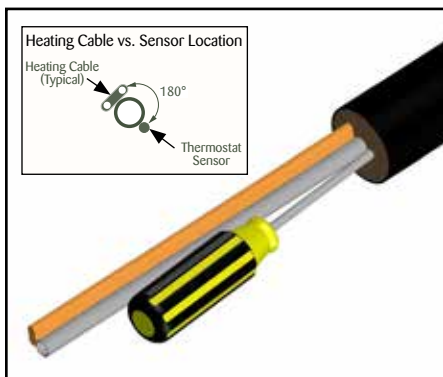

- 3.** Prepare tubing bundle for thermostat sensor by inserting a phillips screwdriver between the process tube(s) and insulation at a point opposite the heating cable. The sensor should be placed 180° around the circumference from the heating cable. Make sure that the entire length of the sensor is in intimate contact with the tube surface. Prevent kinking.

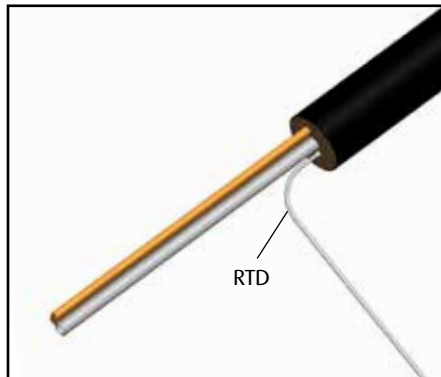

- 4.** Insert the RTD into the prepared hole in the thermal insulation.

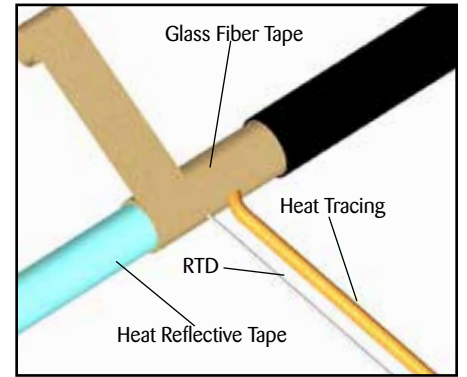

- 5.** Wrap tubes and heat tracing with pass of heat reflective tape (25% overlap). Then wrap with 3 passes of glass fiber tape (50% overlap), or until fiber tape is equal to original bundle insulation thickness.

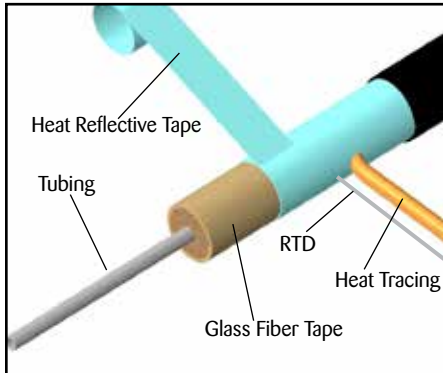

**6.** Complete with 1 additional pass of heat reflective tape.

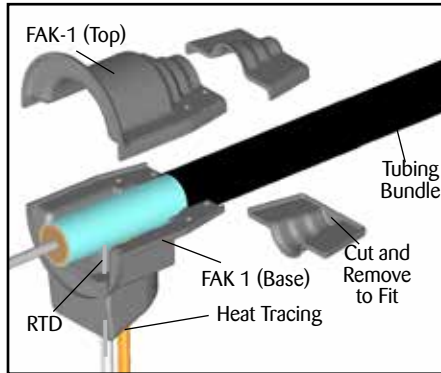

**7.** Cut FAK-1 top and base ends to match outside diameter of tubing bundle and remove end pieces.

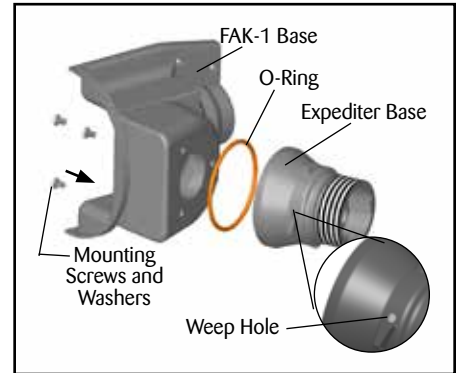

**8.** Mount Expediter Base with O-Ring to FAK-1 (bottom) base cover using (3) M5 mounting screws and lock washers (included). Punch out weep hole.

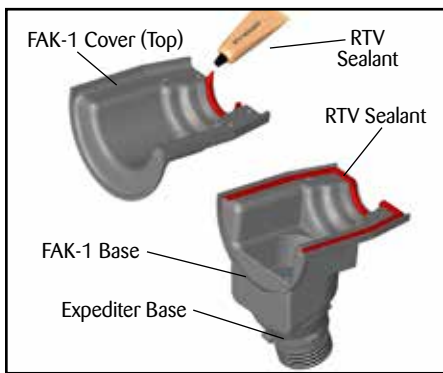

**9.** Form a gasket by applying RTV sealant to FAK-1 base (bottom) and cover (top).

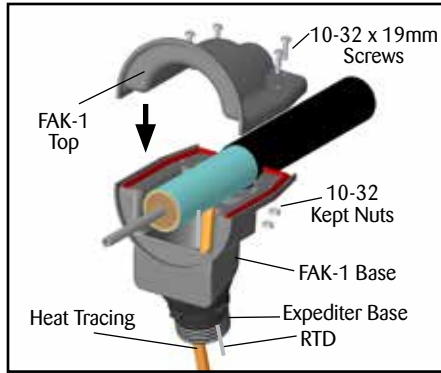

**10.** Fit tubing bundle to FAK-1. Inspect bundle entry into FAK-1 for tight fit. Screw down firmly with screws provided.



**11.** For HPT and FP cable, exchange grommet in Terminator with GRW-GT2 provided in PETK-3-ECM.

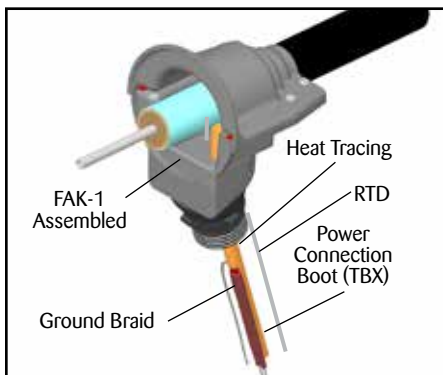

**12.** Trim heat tracing to 180 mm minimum from expediter base. Terminate heat tracing with appropriate PETK termination kit. Refer to PETK installation instructions for details not addressed here.

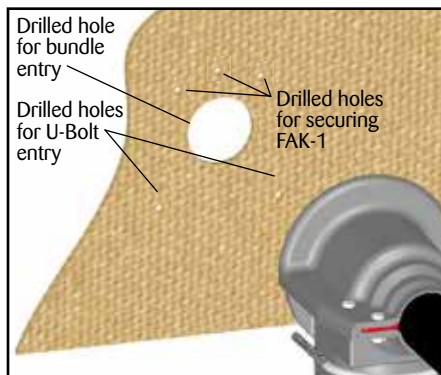

**13.** Drill hole matching bundle diameter into bulkhead. Mark location for U-Bolt entry and FAK-1 securing screws and drill 7 mm holes through bulkhead.

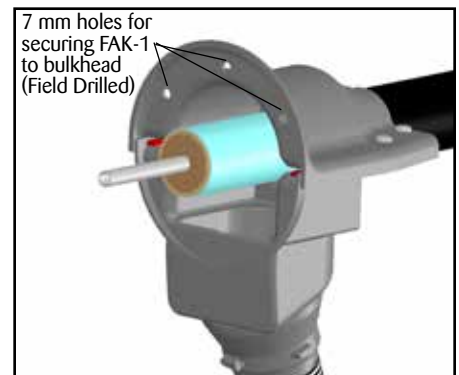

**14.** Pre-drill FAK-1 with 7 mm holes (to match drilled holes in bulkhead) for securing FAK-1 to bulkhead.





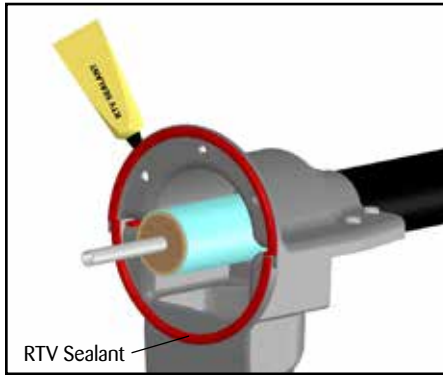

**15.** Apply RTV bead to back of FAK-1 flange prior to securing to bulkhead.

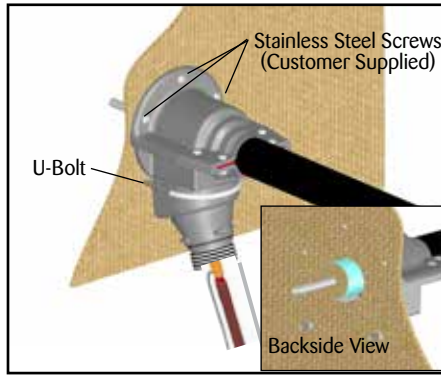

**16.** Secure FAK-1 to bulkhead using (3) three stainless steel screws (Not Included - Customer Supplied) and U-Bolt as shown.

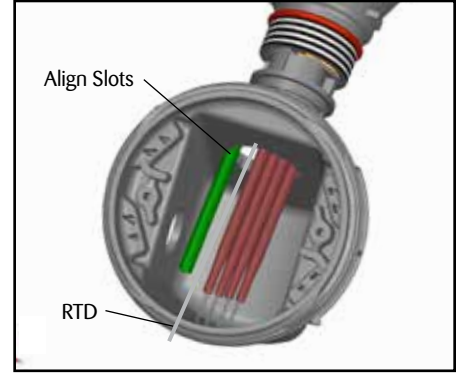

**17.** Mount junction box on expediter making sure to align slots to properly orient junction box base.



**18.** Remove M25 dust cap. Install M25 power gland (order separately) and M25 blind plug.



**19.** Install ECM electronic control module and complete system wiring. Terminal set screws shall be tightened to a torque value of 1,4 Nm (12,4 lb-in). See wiring details. Set ECM modules electronic control and/or control limiter at desired setpoints.



**20.** Use the rotary switches for setting Control and Limit Temperature, (Celsius or Fahrenheit) and Auto or Manual reset (Control switches on Type "C", Limiter switches on Type "L" and both on Type "CL"). Refer to ECM user manual for further details.

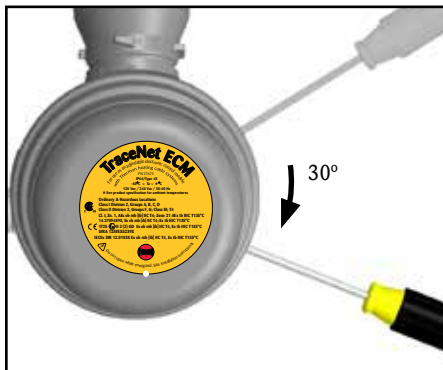

**21.** Install junction box lid and twist hand tight. Insert screwdriver into ratchet slot located on side of junction box base to tighten. Use screwdriver to ratchet on junction box lid. Lid will rotate 30° for tight seal. To remove lid, repeat step 21 in opposite direction.

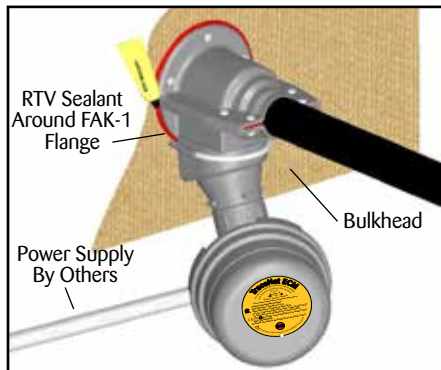

**22.** Apply RTV bead around FAK-1 flange. Completed Terminator with ECM Electronic Controller and FAK-1 for bulkhead entry of Electrically Heated TubeTrace Bundles.

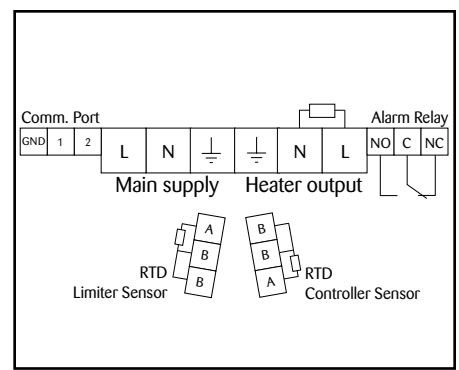

## Wiring Details

Connection (for Heat Trace, RTD Sensor Leads, Alarm and/or Communication Connections)



**THERMON . . . The Heat Tracing Specialists®**

100 Thermon Dr. • PO Box 609 • San Marcos, TX 78667-0609

Phone: 512-396-5801 • Facsimile: 512-396-3627

**1-800-820-HEAT** • In Canada call **1-800-563-8461**

ISO 9001  
REGISTERED

Specifications and information are subject to change without notice. Form PN50088-1213

For the Thermon office nearest you  
visit us at . . .

**[www.thermon.com](http://www.thermon.com)**