

MI Mineral Insulated Heating Cable

INSTALLATION PROCEDURES

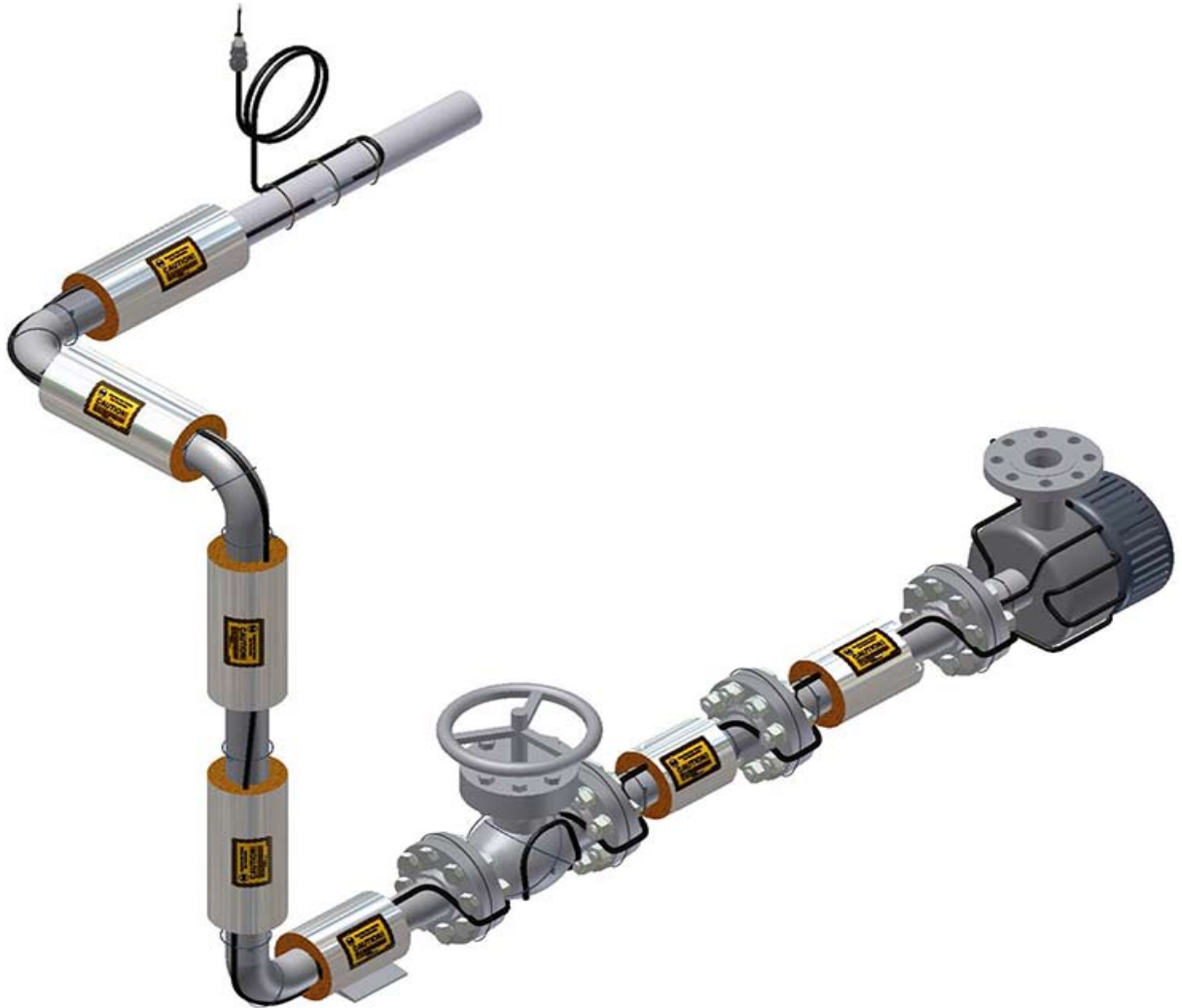

The Heat Tracing Specialists®

MI Mineral Insulated Heating Cable

The following installation procedures are suggested guidelines for the installation of a Thermon MI mineral insulated heat tracing system. Refer to project specifications, if applicable.

The installation must comply with Thermon requirements and be installed in accordance with the regulations as per the norm EN-IEC 60079-14 and EN-IEC 60079-30 for hazardous areas (where applicable), and any other applicable national and local electric codes. **For each installation, the vendor is to provide the design parameters for an engineered system which will designate the cable length, the total cable wattage, and the cold lead length for a specific application.**

Applications . . .

1. MI heating cables are used for freeze protection or temperature maintenance of piping, tanks and instrumentation.
2. Heat tracing cables may be installed in ordinary (nonclassified) and hazardous (classified) locations depending on the specific cable options and approvals.



Due to the risk of electrical shock, arcing and fire caused by product damage or improper usage installation or maintenance, a earth/ground-fault protection device is required for all heat tracing circuits. Bond the metal sheath of the heat tracing cable to a suitable earth terminal.

Site Practice . . .

1. Individuals installing these products are responsible for complying with all applicable safety and health guidelines. Proper Personal Protective Equipment (PPE) should be utilized during installation. Contact Thermon if you have any additional questions.
2. Provide training to employees for understanding the purpose/function of the electrical heat tracing and the electrical power supply/control equipment, and how to recognize and avoid the hazards associated with operation and maintenance.
3. Apply safe work practices including the following:
 - Identify the circuit or equipment to be de-energized and all possible sources of electrical energy supplies to the specific circuit or equipment.
 - Disconnect both legs of the power supply cable at the circuit breakers, disconnect switches, and any other applicable points.
 - Apply lockout/tagout devices according to established procedures.
 - Visually verify that the circuit disconnect devices are open prior to connecting power cable to heat tracers.
 - Test for absence of voltage with an approved voltmeter (where the voltmeter is tested on a known circuit voltage prior to and immediately following application).
 - For protection against accidental energizing of supply conductors, apply temporary jumpers rated for the available fault duty between each supply conductor and earth.

Complete Electric Heat Tracing System¹ . . .

A complete electric heat tracing system may typically include the following components²:

1. MI heat tracing cable.
2. Cable set hot to cold fitting.
3. Cold lead.
4. Stainless steel tie wire (use on 30cm intervals or as required by code or specification).
5. "Electric Heat Tracing" label (peel-and-stick label attaches to insulation weather barrier on 3m intervals or as required by code or specification).
6. Thermal insulation³ and barrier (by others).

The absence of any of these items can cause a system to malfunction or represent a safety hazard.

Notes . . .

1. Thermostat or solid state temperature control device must be used when the system T-rating relies on controlled designs to limit sheath temperature.
2. Illustration depicts a typical MI heating circuit.
3. All heat-traced lines must be thermally insulated.

Illustration A: Typical Heat Tracing Installation

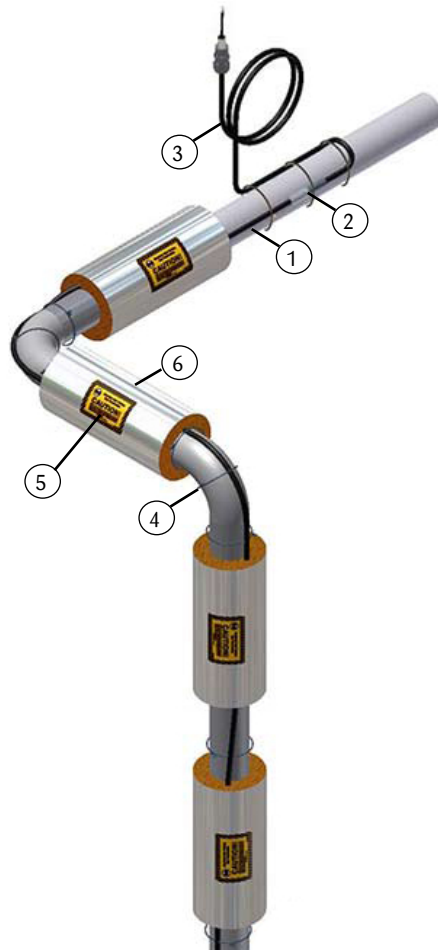

The Heat Tracing Specialists®

INSTALLATION PROCEDURES

Heating Cable Installation General Information

1. Identify the heating cable to ensure the proper type and quantity have been received. Factory-fabricated series circuits will have an imprinted I.D. tag with pertinent data. Compare information on heating cable with packing slip and purchase order to verify receipt of correct shipment.
2. Visually inspect materials for damage incurred during shipment.
3. Store in clean dry place. MI cable set cold lead ends must be kept dry before, during, and after installation.
4. Do not connect power to heating cable while in shipping carton or before installed on pipe/vessel.
5. Test insulation resistance of heating cable set when received, when installed with pipe uninsulated and after thermal insulation has been installed. Using a 500 Vdc megohmmeter, the minimum acceptable reading is 20 megohms between conductor and metallic sheath. IEEE 515 and EN-IEC 60079-30 recommend use of a 1000 Vdc megohmmeter. After the application of thermal insulation, the measured value should not be less than 5 megohms.



6. Heating cables shall not touch, cross over, or overlap itself after installation.
7. Metal structures or material used for the support of or on which cables are sets are installed, are to be bonded to earth in accordance with applicable codes.
8. Minimum installation temperature is -60°C.
9. Do not alter heating cable set length.
10. Do not remove metal tags from heating cable set.
11. Thermostat or solid state temperature control device must be used when the system T-rating relies on controlled designs to limit sheath temperature.

12. Heating cable must not be embedded in the thermal insulation.
13. Heating cable set shall be spaced at least 13 mm from any combustible surface.
14. MI cable set cold lead ends must be kept dry before, during and after installation.
15. Do not damage cable by repeatedly bending and straightening at same location.
16. Do not bend cable less than 15 cm away from hot to cold joint, splice, or end termination.
17. Minimum spacing between cable is 25 mm when installing multiple passes or loops.
18. Refer to Thermon form TMP0066 for information on electrical safety precautions for electrical heat tracing.
19. Provisions must be made to protect MI cable from welding slag, grinders, etc.
20. Keep lids on all power and splice junction boxes. Plug any unused entries.
21. At tee branch in a pipeline, particularly if the branch pipe is smaller than the main pipe, double tracing the smaller pipe with the main heating unit may cause unbalanced pipe temperature. Use caution, check schedules to see if permissible.
22. Any excess heating cable must be distributed evenly along pipe and equipment.
23. Junction boxes must be configured to exclude moisture. If applicable, all conduits feeding into the junction box shall be provided with appropriately rated drains to prevent moisture migration into the junction box.

Types of Heating Cables¹ . . .

MIQ (refer to Form TEP0020U)

CE 1725 Ⓢ II 2 G Ex d IIC T1 to T6, Ta=-60°C to +55°C, IP66 or
II 2 G Ex de IIC T1 to T6, Ta=-60°C to +55°C, IP66 or
II 2 D Ex tD A21 IP66 T450°C to T85°C, Ta=-60°C to +55°C



FMG 09.0006 Ex d (or de) IIC T1 to T6,
Ex tD A21 IP66 T450°C to T85°C

MIS (refer to Form TEP0111U)

CE 1725 Ⓢ II 2G Ex e IIC Gb ISSep12ATEX004U

Notes . . .

1. Refer to the heating cable product specification sheets for temperature ratings as limited by the manufacturer.

MI Mineral Insulated Heating Cable

Before Installing Cable . . .

1. Be sure all piping and equipment to be traced is completely installed and pressure tested.
2. Surface areas where heat tracing is to be installed must be reasonably clean. Remove dirt, rust and scale with a wire brush and oil and grease films with a suitable solvent.
3. Review any applicable local codes and standards prior to beginning the installation.
4. Refer to heat tracing isometric drawings for power point location, equipment allowances, etc. Confirm if MI sets are to be connected in series.
5. Confirm measurements of piping length, including in-line equipment before beginning installation.
6. Test insulation resistance of heating cable set when received using a 500 Vdc megohmmeter. The minimum acceptable reading is 20 megohms between conductor and metallic sheath. IEEE 515 and EN-IEC 60079-30 recommend use of a 1000 Vdc megohmmeter.
(Record 1, Checklist on Page 9)

Initial Installation . . .

1. Determine the orientation of the heating cable(s) on the pipe. The upper 90° of the pipe should be avoided to minimize the possibility of mechanical damage to the heating cable. Also, the sides of the pipe should be avoided since this is the normal location of the insulation seams. Refer to Illustration B for typical heating cable orientations.
2. Begin temporary installation at the proposed hot-to-cold junction (power end) location and lay out heating circuit on the pipe. Refer to Illustration A for temporary installation.
3. Make heating cable allowances for valves, flanges, elbows and supports as per the applicable drawings and table on pages 4 thru 6 of these installation procedures.
4. Fix hot-to-cold junction at 15 cm distance on both sides using stainless steel tie wire or banding. Do not loop back cold lead on small diameter pipes where the minimum bending radius will be exceeded.
5. Install cable with slight "wave" on pipe. Secure cable to pipe with stainless steel tie wire or banding.
6. Adjust cable where necessary.

Illustration A: Temporary Installation . . .

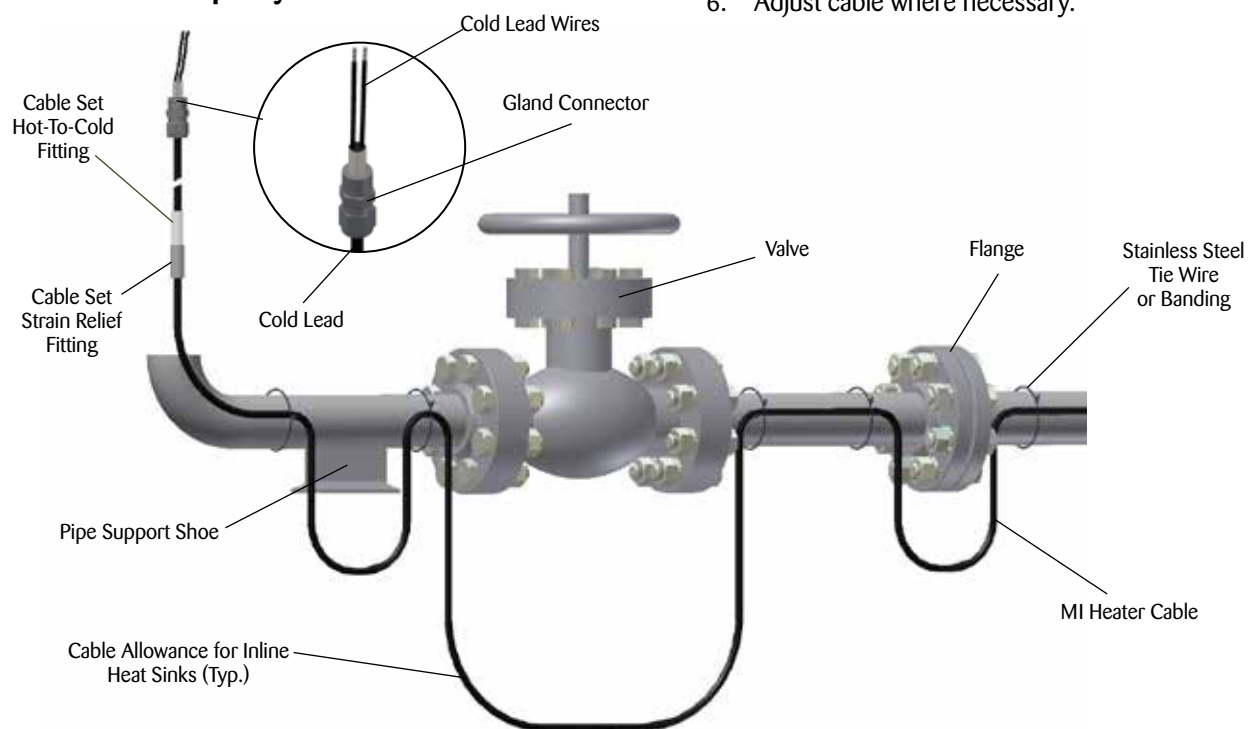
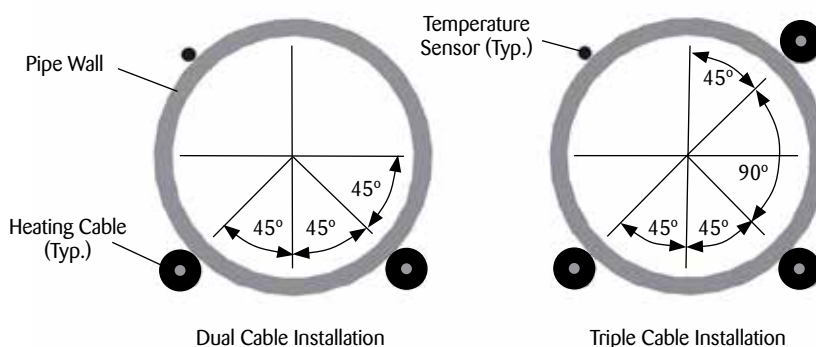

Illustration B: Typical Orientation of Heating Cable and Sensor Location . . .



The Heat Tracing Specialists®

INSTALLATION PROCEDURES

Installation on Elbows, Supports and Flanges . . .

1. Install heating cable in accordance with Illustrations C thru E below. Secure heating cable to piping using stainless steel tie wire or banding.
2. Elbows: Locate the cable on the outside radius of an elbow to provide sufficient heat to compensate for the added piping material. Secure the cable to the pipe on each side of the elbow with stainless steel tie wire or banding.
3. Pipe Supports: Insulated pipe supports require no additional heating cable. For uninsulated supports, allow two times the length of the pipe support plus an additional 40 cm of heating cable.

4. Flanges: Heating cable should maintain contact with flange when bending around pipe flanges to compensate for additional heat loss. In potentially explosive areas, it is recommended to secure MI cable with stainless steel banding at all flanges or any other irregular shaped equipment.
5. Minimum bend radius is 6X cable OD. Do not exceed bend radius when completing installation.

Illustration C: Pipe Elbow . . .

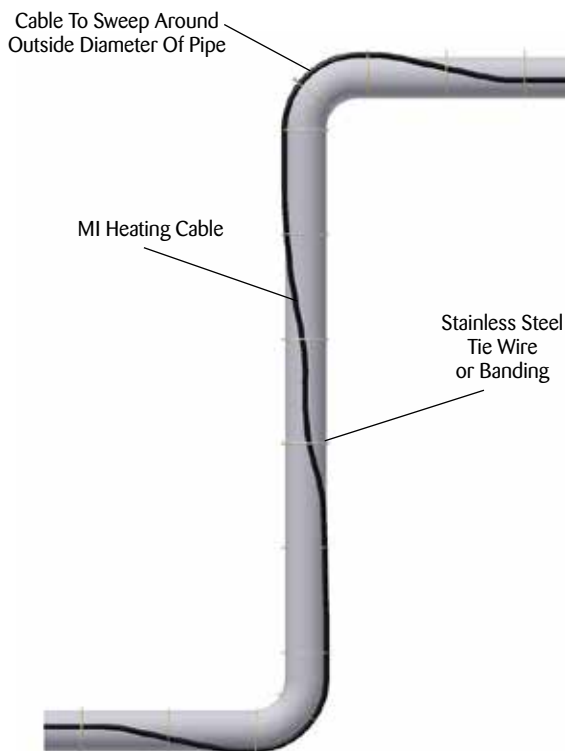

Note:
Slack cable can be taken up by running the cable on the outside radius of the pipe elbows. Running the cable on the inside radius of the pipe elbows will add slack to the cable.

Illustration D: Pipe Support . . .

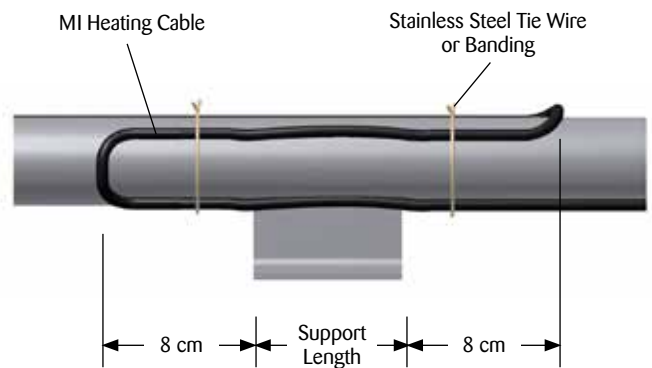

- Notes . . .**
1. Only applicable for pipe ≥ 50 mm.
 2. Loop cable 8 cm past pipe shoe support on both sides.

Illustration E: Pipe Flange . . .



Table 1 Flange Allowance (pair) . . .

| Pipe Size | mm | 12 | 19 | 25 | 32 | 40 | 50 | 80 | 100 | 150 | 200 | 250 | 300 | 350 | 400 | 450 | 500 | 600 | 750 |
|------------------|----|-----|-----|-----|-----|-----|-----|-----|-----|-----|-----|-----|-----|-----|-----|-----|-----|-----|-----|
| Flange Allowance | mm | 150 | 180 | 180 | 180 | 205 | 205 | 255 | 280 | 305 | 330 | 356 | 406 | 457 | 483 | 508 | 533 | 610 | 660 |

MI Mineral Insulated Heating Cable

Installation on Valves and Pumps . . .

1. Install heating cable in accordance with Illustrations F and G below. Secure heating cable to piping using stainless steel tie wire or banding.
2. Additional cable is required to provide extra heat at valves, pumps and miscellaneous equipment to offset the increased heat loss associated with these items. Refer to Table 2 for estimated cable requirements for installation on typical valves and pumps.
3. Install heating cable on valves and pumps utilizing a looping technique (this allows the valve or pump to be removed if required). Do not cross cable.
4. Minimum bend radius is 6X cable O.D. Do not exceed bend radius when completing installation.
5. In potentially explosive areas, it is recommended to secure MI cable with stainless steel banding at all flanges, valves or any other irregular shaped equipment.

Table 2: Valve and Pump Allowances

| Pipe Size mm | Valve Type | | | Pump Type | |
|-----------------|---------------------------|--------------|----------------|--------------|--------------|
| | Screwed or Welded m | Flanged m | Butterfly m | Screwed m | Flanged m |
| 12 | .15 | .30 | 0 | .30 | .61 |
| 19 | .23 | .46 | 0 | .46 | .91 |
| 25 | .30 | .61 | .30 | .61 | 1.22 |
| 32 | .46 | .61 | .30 | .91 | 1.37 |
| 40 | .46 | .76 | .46 | .91 | 1.52 |
| 50 | .61 | .76 | .61 | 1.22 | 1.68 |
| 80 | .76 | 1.07 | .76 | 1.52 | 2.13 |
| 100 | 1.22 | 1.52 | .91 | 2.44 | 3.05 |
| 150 | 2.13 | 2.44 | 1.07 | 4.27 | 4.88 |
| 200 | 2.90 | 3.35 | 1.22 | 5.79 | 6.71 |
| 250 | 3.81 | 4.27 | 1.22 | 7.62 | 8.53 |
| 300 | 4.57 | 5.03 | 1.52 | 9.14 | 10.06 |
| 350 | 5.49 | 5.94 | 1.68 | 10.97 | 11.89 |
| 400 | 6.55 | 7.01 | 1.83 | 13.11 | 14.02 |
| 450 | 7.77 | 8.23 | 1.98 | 15.54 | 16.46 |
| 500 | 8.69 | 9.14 | 2.13 | 17.37 | 18.29 |
| 600 | 10.36 | 10.97 | 2.44 | 20.73 | 21.95 |
| 750 | 12.19 | 12.80 | 3.05 | 24.38 | 25.60 |

Illustration F: Typical Valve Detail . . .

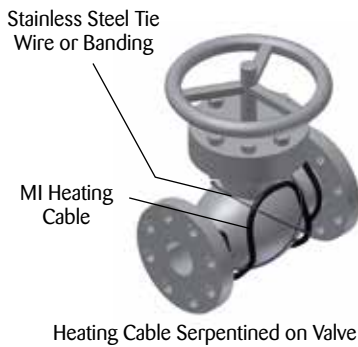

Notes . . .

1. The valve allowance given is the total amount of additional cable to be installed on the valve. If multiple tracers are used, total valve allowance may be divided among the individual tracers. The total valve allowance may be alternated among tracers for multiple valves in a heat trace circuit.
2. Allowances are for 150 pound valves. More cable is required for higher rated valves.
3. Refer to heat trace isometric drawing for project specific allowances.

Illustration G: Typical Pump Detail . . .

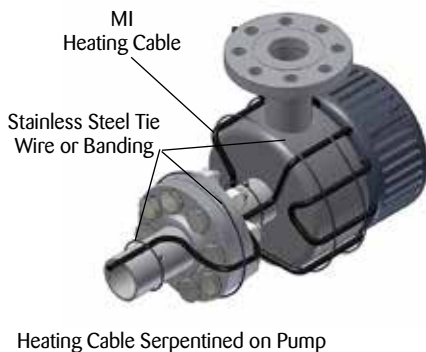

NOTE: Individual MI cable set recommended for pumps.



The Heat Tracing Specialists®

INSTALLATION PROCEDURES

Illustration H: Pipe Hanger . . .

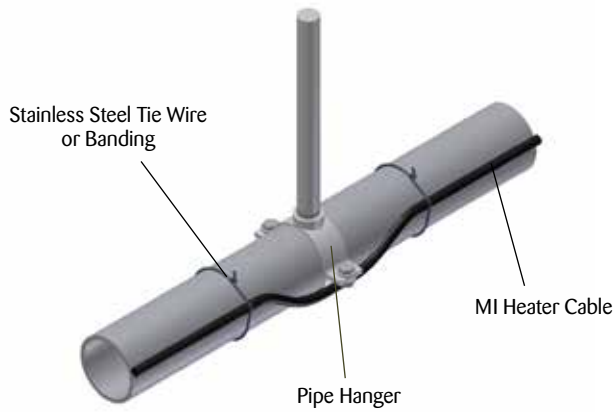
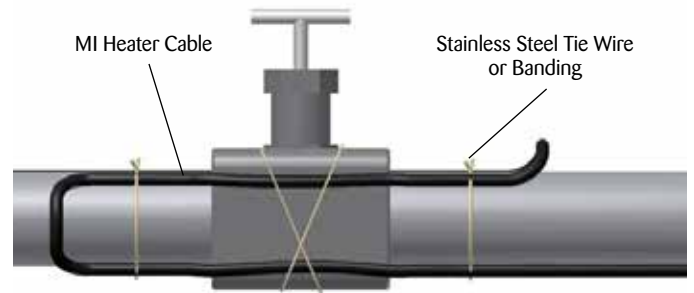

Illustration I: Socket Weld Valve . . .



Notes . . .

1. For small valves (less than 50 mm) it may be impractical to install the correct cable allowance on the valve body itself. It can be installed in a uniform manner across the valve and either side of the pipe as shown above . . .
2. At tee branch pipe line (less than 50 mm) if the branch pipe is double traced and the main pipe is single traced, then there is no additional requirement for cable allowance for valve.

Installation on Tanks and Vessels . . .

Always install MI cable longitudinally on surface of tanks or vessels. Never spiral wrap MI around circumference of tanks or vessels.

MI Mineral Insulated Heating Cable

Completing the Installation . . .

1. Begin final cable attachment by securing the end of circuit and working back toward the power supply.
 - MI mineral insulated heating cables are typically installed with tie wires or stainless steel banding at 30 cm intervals. Use only Thermon approved banding. Do not over tighten banding or tie wire. These cables may also be installed with heat transfer compound and metal channels.
 - Avoid crossing series constant watt heating cables.
 - If applicable, refer to installation details provided with the project drawings or contact Thermon for additional information regarding installation.
2. Before making power connections, the MI cable should be tested to ensure electrical integrity with at least a 500 Vdc megohmmeter (megger) between the conductors and the metal sheath. IEEE 515 and EN-IEC 60079-30 recommend a test voltage of 1000 Vdc for mineral insulated cable. Minimum resistance should be 20 megohms.
(Record 2, Checklist on Page 9)
3. MI series resistance heating circuits are typically prefabricated at the factory. Junction boxes to complete a typical MI circuit connection to power may not be supplied as part of the system. For Ex d sets, use only Ex d connection fittings. For Ex de sets, use only Ex e connection fittings. Refer to Installation instructions included with power/splice enclosures or contact Thermon for additional information.
4. Route MI cable set cold lead(s) into junction box hub(s). Slowly tighten gland connector with set of wrenches until ferrule begins to make positive contact with cold lead sleeve and cold lead can not be moved by hand. Then tighten fitting 1/8 additional turn.
5. Secure temperature sensor (if required) to pipe utilizing stainless steel banding. Locate temperature sensor as shown in Illustration B.

Illustration J: Typical Installation. . .

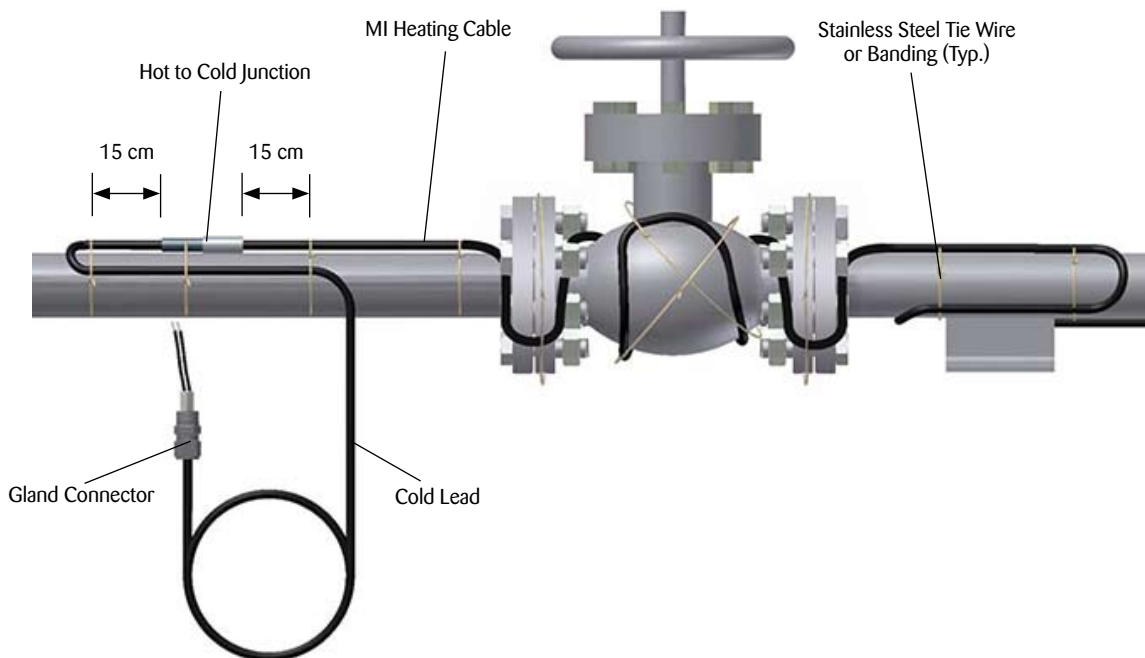

The Heat Tracing Specialists®

INSTALLATION PROCEDURES

Circuit Protection Requirements . . .

1. Over-current protection (typically circuit breakers) is required for each branch circuit. This protection must isolate all power conductors from the supply.
2. For typical installations (with TT and TN grounding systems), a means of protection against earth faults is required that includes a residual-current protective device for each branch circuit. For fixed-level ground-fault circuit interrupters (such as GFCI circuit breakers), a minimum 30 mA trip level is recommended. The preferred trip level for adjustable devices is 30 mA above any inherent capacitive leakage characteristic of the heater as specified by the heat tracing supplier. Where conditions of maintenance and supervision ensure that only qualified persons will service the installed systems, and continued circuit operation is necessary for the safe operation of the equipment or processes, earth-fault detection without interruption is acceptable if alarmed in a manner to assure an acknowledged response.
3. For IT grounding systems, a means of protection against earth faults is required that includes an electrical insulation monitoring device that shall disconnect the supply whenever the electrical resistance is not greater than 50 ohms/volt of rated voltage.

Thermal Insulation . . .

1. The need for properly installed and well-maintained thermal insulation cannot be overemphasized. Without insulation, heat losses are generally too high to be offset by a conventional heat tracing system.
2. In addition to piping and in-line equipment such as pumps and valves, all heat sinks must be properly insulated. This includes pipe supports, hangers, flanges and, in most cases, valve bonnets.
3. Regardless of the type or thickness of insulation used, a protective barrier should be installed. This protects the insulation from moisture intrusion, physical damage and helps ensure the proper performance of the heat tracing system. Seal around all penetrations through the thermal insulation.
4. After the installation of the thermal insulation and weather barrier but BEFORE ENERGIZING THE HEATING CIRCUIT, the megohmmeter test should be repeated. The measured value should not be less than 5 megohms. This should call attention to any damage to the heating cable that may have occurred during the insulation installation. **(Record 3, Checklist on Page 9)**
5. Apply caution labels to insulation weather barrier at required intervals along pipe.

Final Inspection and Documentation . . .

1. It is recommended that the circuit be temporarily energized so that the volts, amps, pipe temperature and ambient temperature may be recorded. This information may be of value for future reference and should be maintained for the historical operating data log. **(Record 4, Checklist on Page 9)**
2. A sample historical operating data log form is included in the Electric Heat Tracing Maintenance and Troubleshooting Guide, Thermon Form TEP0066.
3. Stabilized design can be used for MI heating cables without a limiting device to determine the T-class through the use of the Thermon CompuTrace software or Thermon Engineering.
4. The maximum temperatures provided by Thermon's CompuTrace software and by Thermon engineering are calculated to the methods and requirements of EN-IEC 60079-30.
5. If stabilized design is used, the end user must record the system parameters and the area T-class, and keep these records for the time the heating cable is in operation.
6. Inspect system on a regular basis at least once per year. Record all information after conducting test. If the system fails any test, refer to Thermon's Maintenance and Trouble Shooting Guide for assistance. De-energize circuits affected and make the necessary repairs immediately.
7. Verify the setting of the maximum control device, if provided to limit the T-rating for the circuit design, to insure it limits the maximum surface temperature to be in compliance with clause 4.4.3 of EN-IEC 60079-30-1.

Maintenance and Repair . . .

1. Refer to form TEP0066-Electric Heat Tracing Maintenance and Trouble Shooting Guide.



Due to the risk of electrical shock, arcing and fire caused by product damage or improper usage installation or maintenance, a earth/ground-fault protection device is required for all heat tracing circuits. Bond the metal sheath of the heat tracing cable to a suitable earth terminal.

Checklist for Installation of MI Cables

| General Information | | | | | |
|--|-----------------------|------------------------|------------------------------------|--------------------------------|---|
| Project Number: | | Electrical Contractor: | | | |
| Unit Number: | | Reference Number: | | | |
| Customer Ref. Number: | | Inspector: | | | |
| Record 1: Prior to Installation | | | | | |
| Cable Type: | | | Insulation Resistance (M Ohms): | | |
| Reel Length (M): | 1 | 2 | Single Phase | L-Earth | |
| | | | | L ₁ -Earth | |
| Reel Number: | 1 | 2 | 3 Phase | L ₂ -Earth | |
| | | | | L ₃ -Earth | |
| Tested By/Date: | | | Witnessed By/Date: | | |
| Record 2: After Cable Installation | | | | | |
| Line Number: | | | Junction Box Number: | | |
| Equipment Number: | | | Unused Entries Plugged Off: | | |
| Circuit/Heater Number: | | | Heater Length (M): | 1 | 2 |
| Circuit Switch Number: | | | Insulation Resistance (M Ohms): | | |
| Metal Sheath Connected to Earth/Ground: | | | Single Phase | L-Earth | |
| | | | | L ₁ -Earth | |
| Thermostat Number: | | | 3 Phase | L ₂ -Earth | |
| | | | | L ₃ -Earth | |
| Tested By/Date: | | | Witnessed By/Date: | | |
| Record 3: After Thermal Insulation is Installed | | | Insulation Watertight: | | |
| Insulation Resistance (M Ohms): | | | Electrical Loop Resistance (Ohms): | | |
| Single Phase | L-Earth | | Single Phase | L-L | |
| 3 Phase | L ₁ -Earth | | 3 Phase | L ₁ -L ₂ | |
| | L ₂ -Earth | | | L ₂ -L ₃ | |
| | L ₃ -Earth | | | L ₃ -L ₁ | |
| Tested By/Date: | | | Witnessed By/Date: | | |
| Record 4: Final Commissioning | | | | | |
| Panel Number: | | | Ambient Temp. (°C): | | |
| Breaker Number: | | | Pipe Temp. (°C): | | |
| Volts: | | | Recorded Amps (after 5 min.): | | |
| Tested By/Date: | | | Witnessed By/Date: | | |

***NOTE: Minimum acceptable insulation resistance should be 20 megohms for Records 1 and 2 and 5 Megohms for Record 3.**

For additional product information on Thermon heating cables, refer to the individual product specifications.

Electric Heat Tracing Maintenance and Troubleshooting Guide (refer to Form TEP0066)

MIQ (refer to Form TEP0020U)

MIS (refer to Form TEP0111U)



THERMON . . . The Heat Tracing Specialists®
www.thermon.com

European Headquarters
Boezemweg 25 • PO Box 205
2640 AE Pijnacker • The Netherlands
Phone: +31 (0) 15-36 15 370

Corporate Headquarters
100 Thermon Dr. • PO Box 609
San Marcos, TX 78667-0609 • USA
Phone: +1 512-396-5801

ISO 9001
REGISTERED

Specifications and information subject to change without notice. PN50273U-0912

For the Thermon office nearest you
visit us at . . .
www.thermon.com