

# Terminator™ ZE-B Beacon

LED End of Circuit Light Kit

INSTALLATION PROCEDURES



**The Heat Tracing Specialists®**

# Terminator™ ZE-B Beacon

## INSTALLATION PROCEDURES

### Receiving, Storing and Handling . . .

1. Inspect materials for damage incurred during shipping.
2. Report damages to the carrier for settlement.
3. Identify parts against the packing list to ensure the proper type and quantity has been received.
4. Store in a dry location.

### Kit Contents . . .



Item	Quantity	Description
1	1	Expediter Assembly Grommet Compressor Grommet Support Base with O-Ring
2	1	Light Module Cover
3	1	Banding Guide
4	1	Banding
5	1	LED Light Module

### Order Separately . . .

#### SCTK Connection Termination Kits (per cable)

SCTK-1 for BSX, RSX, VSX

SCTK-2 for KSX, HTSX

SCTK-3 for FP, HPT

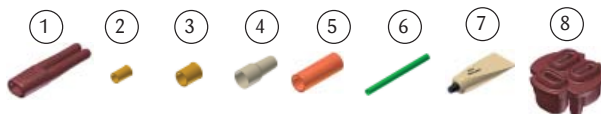

Item	Quantity	Description
1	3	Splice Connection Boots
2	2	Small Crimps
3	1	Large Crimp
4	2	Small Crimp Insulators
5	2	Silicone Caps
6	3	Ground Sleeves (not used with ZE-B Kits)
7	1	RTV Tube
8	1	GRW-G (FP and HPT only)

### Dimensions . . .



### Installation Precautions . . .

- To minimize the potential for arcing and fire caused by product damage or improper installation use ground-fault protection.
- Installation must comply with Thermon requirements and be installed in accordance with the applicable national and local codes.
- Component approvals and performance ratings are based on the use of Thermon specified parts only.
- De-energize all power sources before opening enclosure.
- Avoid electrostatic charge. Clean only with a damp cloth.
- Keep ends of heating cable and kit components dry before and during installation.
- Individuals installing these products are responsible for complying with all applicable safety and health guidelines. Proper personal protective equipment, or PPE, should be utilized during installation. Contact Thermon if you have any additional questions.

### Certifications/Approvals . . .

IP66 -60°C ≤ Ta ≤ +45°C  
Ordinary & Hazardous Locations

IECEx FMG 10.0022X Ex eb mb IIC T6, Ex tb IIIC T85°C

CE 1725 Ex II 2 GD Ex eb mb IIC T6, Ex tb IIIC T85°C, FM 10ATEX0058X

### Tools Required . . .



**Note:** Crimp Tool - Ideal 30-429 or factory approved alternate.



The Heat Tracing Specialists®

# Terminator™ ZE-B Beacon INSTALLATION PROCEDURES

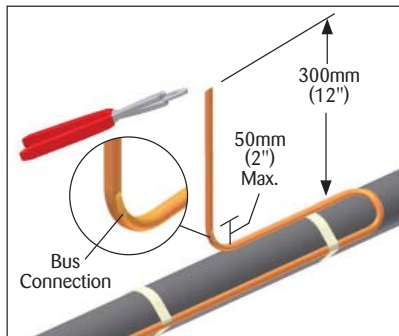

**1.** Locate bus connection (HPT and FP only) and cable as shown. Cut end of cable at angle to aid in piercing grommet. Leave additional cable for expansion loop.

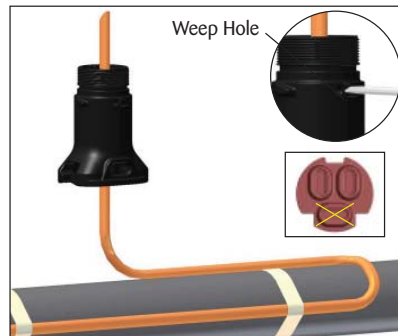

**2.** Insert cable into expediter. If mounted on bottom of pipe, punch out weep hole.

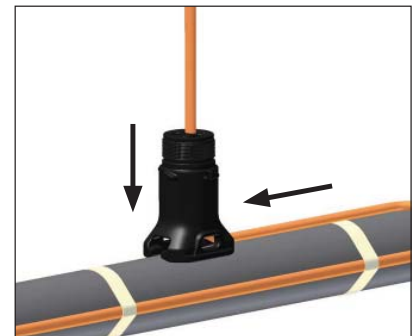

**3.** Slide expediter toward pipe and route cable through support base entry.



**4.** Insert banding guide into expediter and snap into place.



**5.** Mount expediter to pipe using pipe band. Do not band over cable.

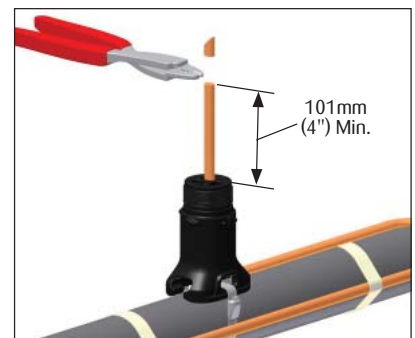

**6.** Cut off end of cable.

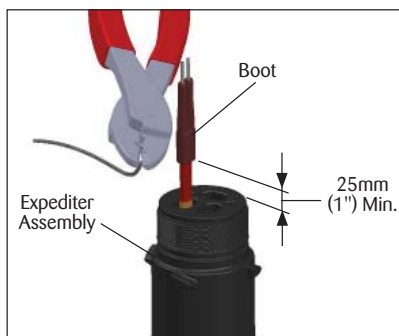

**7.** Terminate cable with appropriate SCK termination kit. Refer to SCK installation instructions. Push excess cable back through expediter. Remove braid pigtail. Tape cable expansion loop to pipe.

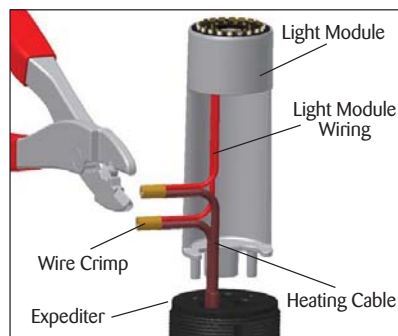

**8.** Connect heating cable to light module wires using small crimps. Discard large crimp. See wiring details.

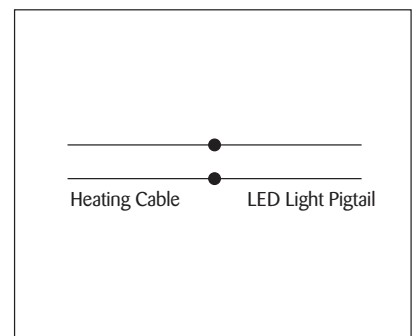

**Wiring Details for LED Light**



The Heat Tracing Specialists®

# Terminator™ ZE-B Beacon

## INSTALLATION PROCEDURES

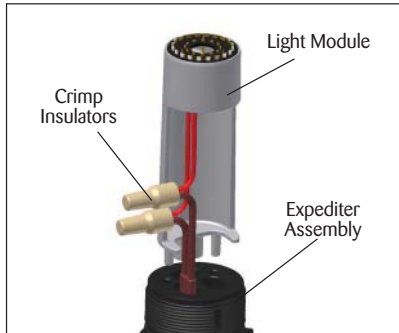

9. Snap on crimp insulators.

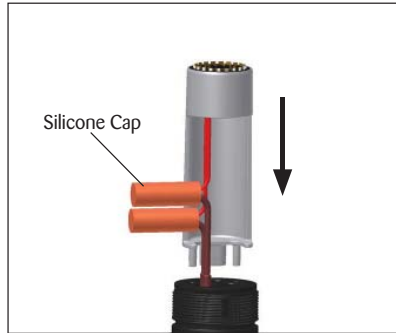

10. Slide silicone caps over crimp insulators. Install Light Module to Expediter.

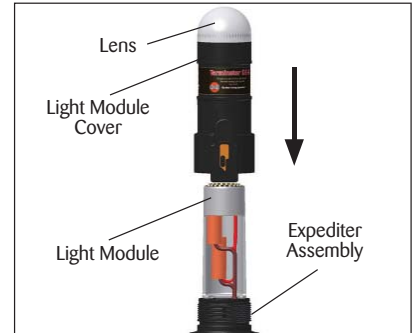

11. Arrange crimped leads to fit inside light module base. Slide the light module cover over light module.



12. Engage threads. Rotate light module cover clockwise and tighten cap securely. Make sure latch mechanism is in the locked position.

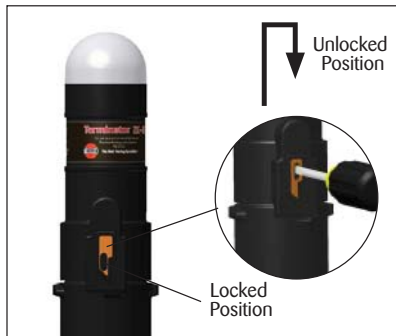

13. To remove cap, de-energize circuit, lift latch mechanism, and unscrew cap.



**THERMON . . . The Heat Tracing Specialists®**  
www.thermon.com

European Headquarters  
Boezemweg 25 • PO Box 205  
2640 AE Pijnacker • The Netherlands  
Phone: +31 (0) 15-36 15 370

Corporate Headquarters  
100 Thermon Dr. • PO Box 609  
San Marcos, TX 78667-0609 • USA  
Phone: +1 512-396-5801

ISO 9001  
REGISTERED

Specifications and information subject to change without notice. PN50844U-1110

For the Thermon office nearest you  
visit us at . . .  
[www.thermon.com](http://www.thermon.com)