

**Type FLX™ Freezer Floor
Frost Heave Protection
DESIGN GUIDE**



The Heat Tracing Specialists®

Commercial Products

Type FLX™ Freezer Floor Frost Heave Protection **DESIGN GUIDE**

Contents

Introduction	2
Application Information	2-3
Product Description	
Characteristics	
Approvals	
Basis for a Good Design	3
Frost Heave Protection Design Outline	3-6
Step 1: Establish Design Conditions	
Step 2: Determine Conduit Spacing	
Step 3: Branch Circuit Breaker Sizing	
Step 4: Determine the System Layout	
Step 5: Establish Control Method to Operate System	
System Components	7
Frost Heave Protection Bill of Materials	7
General Specification	8

For additional information about frost heave protection of freezer floors with heat tracing contact Thermon.

Freezer Frost Heave Protection

Introduction . . .

The substrata of freezer floors can withstand cold temperatures for a period of time; however, the ground temperature will eventually drop below freezing. At that point, if water is present in the substrate, frost heaving of the freezer floor will occur. FLX cables, when run in conduit in the substrate, provide frost heave protection by maintaining the ground temperature above freezing.

Small or large frost heave protection applications can be easily designed utilizing FLX self-regulating heating cables. Establishing the proper design, procurement and installation of materials for a project will ensure a successful heat tracing system installation.

The information contained within this design guide will assist engineers and contractors in establishing a successful electric heat tracing design and installation based on:

- Freezer temperature
- Available power supply
- Freezer size
- Substrate makeup
- Monitoring/control requirements

After following the designated steps in this design guide, the engineer/contractor will be able to design, specify or establish a bill of materials for a freezer floor frost heave protection system.

If design parameters are different than those in this design guide, contact your local Thermon factory representative for additional information.

Characteristics . . .

Bus wire	16 AWG nickel-plated copper
Heating core	radiation cross-linked polyolefin
Primary dielectric insulation	radiation cross-linked polyolefin
Metallic braid	12 AWG (equivalent size) tinned copper
Outer jacket	OJ, polyolefin
Minimum bend radius	1.25" (32 mm)
Supply voltage	110-120 or 208-277 Vac
Circuit protection	30 mA ground-fault protection required
Max. operating temperature (power-on)	150°F (65°C)
Max. exposure temperature (power-off)	185°F (85°C)
Minimum installation temperature	-60°F (-51°C)

Product Description . . .

FLX self-regulating heating cable includes a parallel circuit construction that allows the cable to be cut to length and terminated in the field. The semiconductive heating matrix provides the self-regulating feature. FLX heating cable varies its heat output to compensate for the surrounding conditions along the entire length of a circuit.

Whenever the heat loss of the freezer floor increases, the heat output of the cable increases. Conversely, when the heat loss decreases, the cable reacts by reducing its heat output. This self-regulating feature occurs along the entire length of a heat tracing circuit to ensure each point receives the required amount of heat while conserving energy.

FLX 8 heating cables are rated for nominal heat outputs of 5.5 W/ft in conduit at 40°F (18 W/m in conduit at 4°C) when powered at 110 to 120 Vac or 208 to 277 Vac. FLX self-regulating cables include a tinned copper braid to provide grounding and polyolefin outer jacket for additional mechanical protection for the cable.

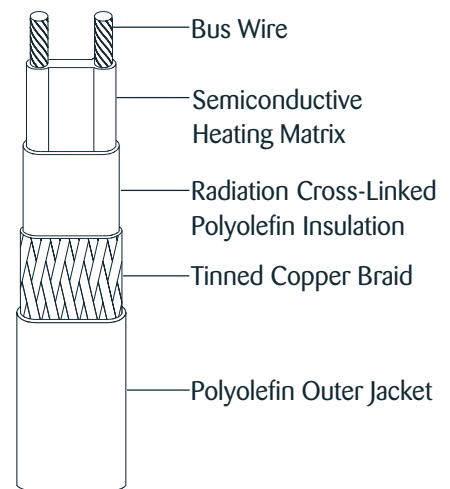

The Heat Tracing Specialists®

Product Approvals . . . Tests . . . Compliances

Thermon's Type FLX self-regulating heating cable carries the following major agency approval:



Underwriters Laboratories Inc.®

In addition to the numerous agency tests performed, FLX has also passed the testing guidelines outlined in IEEE Standard 515.1, Recommended Practice for the Testing, Design, Installation, and Maintenance of Electrical Resistance Heat Tracing for Commercial Applications.

FLX Cables Meet or Exceed the Following Tests . . .

Test	Standard Followed
Dielectric Withstand	IEEE 515.1 (4.2.1)
Water Resistance	IEEE 515.1 (4.2.3)
Thermal Stability	IEEE 515.1 (4.2.6)
Flammability	IEEE 515.1 (4.2.7)
Deformation	IEEE 515.1 (4.2.8)
Cold Bend	IEEE 515.1 (4.2.10)
Moisture Resistance	IEEE 515.1 (4.5.1)
Pull Strength	IEEE 515.1 (4.5.2)

Basis for a Good Design . . .

As freezers and refrigerated facilities are typically maintained at temperatures below freezing, the substrata below these facilities results in temperatures below freezing. If moisture is present, it will begin to freeze, expand and eventually cause the floor to heave.

Due to differences found in construction, substrata and power availability, no particular design may be effective in all situations to maintain subsoil temperatures above freezing.

This design guide helps the reader evaluate different scenarios so that each project may be designed to meet specific requirements.

Frost Heave Protection Design Outline . . .

The following steps outline the design process for an FLX 8 freezer floor frost heave protection system (required for each separate facility):

Step 1: Establish Design Conditions

Collect relevant project data:

- a. Facility size
 - Length of area
 - Width of area
- b. Facility substrate
 - Concrete cap thickness
 - Insulation type and thickness
 - Substrate type and thickness
- c. Temperature
 - Facility temperature

Step 2: Determine Conduit Spacing

Based on:

- a. Thermal insulation
 - Type of insulation
 - Thickness of insulation
- b. Minimum operating temperature

Step 3: Determine Maximum Circuit Length and Electrical Load

Based on:

- a. Operating voltage
- b. Branch circuit breaker size
- c. Circuit lengths

Step 4: Determine the System Layout

Review freezer floor plans to establish:

- a. Conduit layout
- b. Junction box locations
- c. Pull box locations

Step 5: Establish Control Method Needed to Operate System

- a. Thermostatic control
- b. RTDs with HeatChek® systems

The step-by-step procedures which follow will provide the reader with the detailed information required to design and specify a fully functional frost heave protection system.

Freezer Frost Heave Protection

Step 1: Establish Design Conditions

The following data is required in determining the heat load for a frost heave protection system.

Size of Facility . . . Total surface area including physical dimensions of all areas with floor temperatures expected to be at or below freezing.

Floor Substrata . . .

- **Finished Floor**—In freezer applications, this surface is typically concrete. As this surface does not generally affect the overall heat load, this design guide assumes a 4" (10 cm) layer of concrete.
- **Type and Thickness of Insulation**—This design guide is based on industry standards with a thermal conductivity of 0.20 Btu in/hr ft² °F. The design selection tables in Step 2 allow for an insulation thickness of both 4" and 6" (10 cm and 15 cm).
- **Substrate**—Generally composed of concrete or gravel, the heating cable is placed within this layer, allowing even heat distribution between heating passes.

Facility Operating Temperatures . . . Determine the low operating temperature of the storage facility. It is not uncommon for the required operating temperatures to change; therefore, use the lowest expected temperature for calculating heat loads.

Step 2: Determine Conduit Spacing

The primary factors in determining heat and corresponding conduit spacing requirements in frost heave protection systems are thermal insulation and minimum operating temperatures.

Insulation does not stop the flow of heat; it merely slows the heat transfer down depending on the type and thickness of insulation present.

This guide assumes a core soil temperature of 55°F (13°C) for below-grade installations. As with installations above grade, thermal insulation around the perimeter should be considered.

The primary objective of the heating system is to replace the heat lost through the thermal insulation and maintain temperatures below the insulation at or above 40°F (4°C). This is generally accomplished by placing the conduits on 4' to 8' (1.2 m to 2.4 m) center-to-center spacing.

Using the design criteria provided, refer to Design Selection Tables 2.0 to determine the required conduit spacing. A 50% safety factor has been included in the values shown.

The design selection chart provides specific heat loss requirements based on the following:

- Freezer operating temperatures
- Insulation thickness
- Fixed insulation thermal conductivity

If the thermal insulation type or thickness for your specific needs is different from that shown, contact your local Therman factory representative for design assistance.

Table 2.0 Design Selection

Freezer Operating Temperature	Conduit Spacing ft (m)	
	Floor Insulation ¹ (R-20)	Floor Insulation ¹ (R-30)
-40°F (-40°C)	--	4.5 (1.4)
-20°F (-29°C)	4.0 (1.2)	6.0 (1.8)
-10°F (-23°C)	5.0 (1.5)	7.5 (2.3)
0°F (-18°C)	6.0 (1.8)	8.0 (2.4)
10°F (-12°C)	8.0 (2.4)	8.0 (2.4)
20°F (-6°C)	8.0 (2.4)	8.0 (2.4)

Notes . . .

1. Insulation values are based on industry standards with a thermal conductivity of 0.20 Btu in/hr ft² °F. Insulation with R-20 and R-30 are based on 4" and 6" (10 cm and 15 cm) thickness respectively.



The Heat Tracing Specialists®

Step 3: Maximum Circuit Lengths and Total Heating Load

Thermon's Type FLX heating cable is designed to operate on standard line voltages of 120, 208, 220, 240 or 277 Vac.

Cable selection is contingent upon the following variables:

- Operating voltage
- Available branch circuit breaker size
- Circuit length requirements
- Maximum allowable circuit length

Table 3.0 provides the maximum continuous circuit length allowable based on line voltage and the circuit breaker rating. A 40°F (4°C) start-up is assumed.

Table 3.0 Cable Selection

Catalog Number	Service Voltage	Maximum Circuit Length		
		15 Amp	20 Amp	30 Amp
FLX 8-1	110-120	130 (40)	175 (53)	220 (67)
FLX 8-2	208-277	260 (80)	350 (105)	440 (135)

Notes . . .

- Ratings are based on dry conduit conditions (no moisture or water inside conduit). Contact Thermon if start-up conditions are other than 40°F (4°C).
- The National Electrical Code and Canadian Electrical Code require ground-fault protection of equipment for each branch circuit supplying electric heating equipment. Check local codes for ground-fault protection requirements.

Formula 3.0 Estimating Circuit Length

Circuit Length = (Freezer Floor Area ft² ÷ Conduit Spacing) + End Allowances + Termination Allowances

Every heat tracing circuit will require some additional heating cable to make the various terminations. Use the following guidelines to determine the amount of extra cable required:

- End Allowances . . . Allow an additional 4' of FLX cable for each end. Length of cable required to extend from conduit located in subfloor to the junction box located above the finished floor. (See Detail Below)
- Termination Allowances . . . Allow an additional 2' of FLX cable for each termination. Length of heating cable inside junction box.

Option: FLX 8 Self-Regulating heating cable may extend between junction boxes inside a protective conduit thus reducing the need to make a termination at each junction box. If this approach is used, the termination allowance becomes the center-to-center distance between conduits.

Example . . .

Branch circuit requirements of an individual heater circuit are dependent upon the supply voltage and the total length of heater cable installed. Determine an estimated circuit length for an individual circuit by using Formula 3.0.

As an example, assume the freezer floor for a given facility to be 32' x 45' (1440 ft²) with 8' center-to-center conduit spacing. Use Formula 3.0 to determine an estimated circuit length for the individual circuit requirements:

$$\text{Circuit Length} = (1440 \div 8) + 32' + 16'$$

Total footage of FLX can be estimated . . .

$$\text{Total FLX cable required} = 228 \text{ linear feet}$$

Notes . . .

1. End allowance includes 8 junction boxes multiplied by 4 feet each to equal 32 feet.
2. Termination allowance includes 8 terminations multiplied by 2 foot each to equal 16 feet.

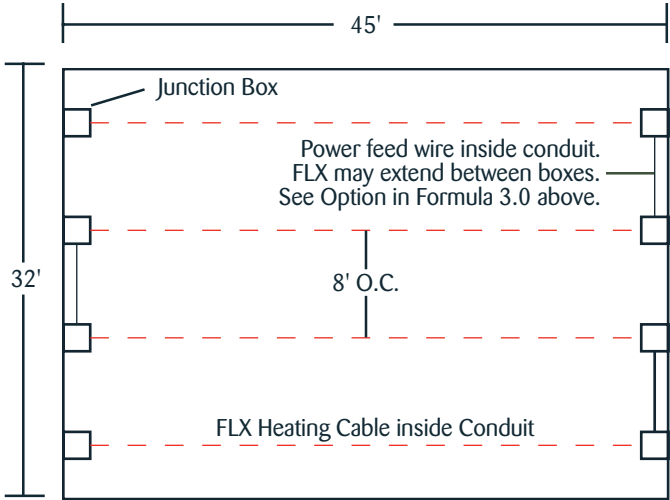

Formula 3.1 Estimating Operating Load

Nominal Electrical Load = (Total Cable Required x 5.5 W/ft)

The total operating load of a FLX frost heave system can be determined by inserting the appropriate values into Formula 3.1.

Example . . .

Using Formula 3.1 total output (in watts) can be estimated . . .

$$\text{Total output} = 228 \times 5.5$$

$$\text{Total output} = 1254 \text{ watts}$$

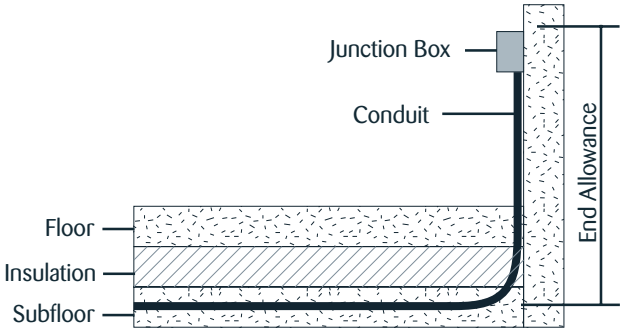

Freezer Frost Heave Protection

Step 4: Determine System Layout

Heating cables used for frost heave protection systems can be installed in metallic or nonmetallic conduits under the insulated floor. These conduits allow the heater cable to be replaced with new cable should the need arise. Conduits used for heating cable should be a minimum of 3/4" inside diameter.

Where the size of the freezer permits, conduit layout can utilize a looping design allowing all junction/pull boxes to be located along one wall. If the length requires, straight line runs locating junction boxes along walls opposite each other may be used. The conduit layout and number of bends should be arranged in order that the pulling force of the heating cable does not exceed 667 newtons (150 pounds) (refer to Details 4.1 and 4.2).

As per the National Electrical Code, Article 348-10, "There shall not be more than the equivalent of four quarter bends (360 degrees total) between pull points, e.g., conduit bodies and boxes."

Location of junction boxes must allow accessibility to the wiring without removing any part of the building or other substance used to establish finished grade. Typically junction boxes are located 12" to 24" (30 to 61 cm) above the finished floor (refer to Detail 4.3).

Once the locations of the junction boxes are known, begin conduit layout using the information provided in the earlier steps.

- Determine layout using center-to-center spacing selected in Step 2.
- Do not exceed continuous circuit lengths shown in Table 3.0.
- For installation in concrete subslab, secure conduit to reinforcing steel using steel tie wire.
- For installation in gravel subslab, secure conduit using the addition of rebar or steel spikes to maintain recommended spacing.

Step 5: Establish Control Method to Operate the System

All frost heave protection systems should be controlled. There are two basic ways to control and monitor a frost heave protection system:

- **Recommended:** Proportional control using a Resistance Temperature Detector (RTD) with HeatChekSystem—Turns system on proportionally based on subfloor temperatures. At maximum heat loss system is 100% on. RTDs, to be located in a minimum of 1-1/4" conduit between electric

- heat tracing conduits, have the ability to limit the cable's power output to closely match heat loss (refer to Detail 5.1).
- **Alternate:** On/Off Thermostatic Control—Turns system on and off based on subfloor temperatures. Sensor is located in 1-1/4" conduit between electric heat tracing conduits (not shown).

Detail 4.1 Looping Design

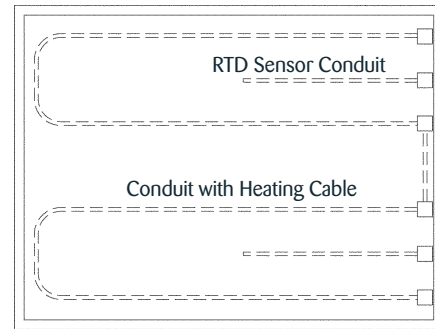

Detail 4.2 Straight Line Design

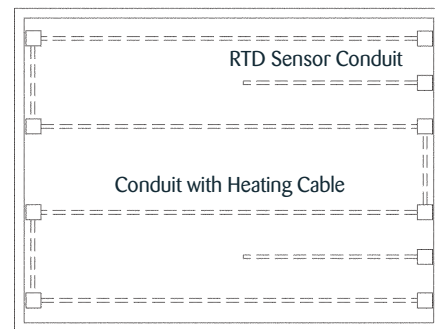

Detail 4.3 Junction Box

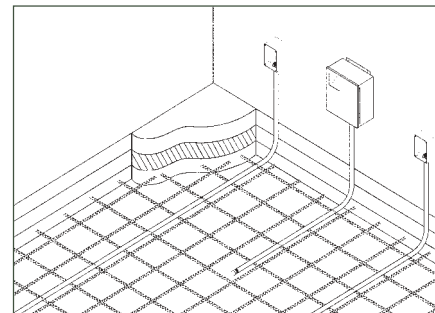

Detail 5.1 HeatChek System

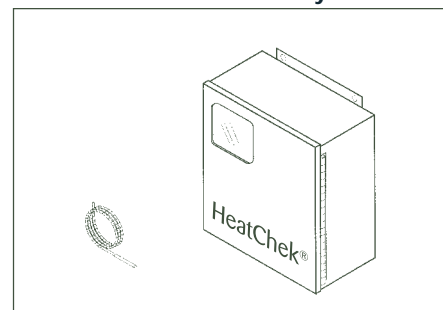

The Heat Tracing Specialists®

DESIGN GUIDE

System Components . . .

A system with Type FLX heating cable for frost heave protection will typically include the following components:

1. **FLX 8** self-regulating heating cable
2. **TBX-3LC** power connection kit
3. **ET-6C** end termination kit
4. **JB-K** nonmetallic junction box
5. **Adjustable Thermostat** (not shown)
6. **RTD-500-3** resistance temperature detector
7. **HeatChek** control and monitoring system
8. **CL** “Electric Heat Tracing” caution labels peel and stick to junction boxes, power distribution and control panel(s), or as required by code or specification (not shown)

Frost Heave Protection Bill of Materials . . .

Use the design outline steps on page 3 and the detailed steps on pages 4 through 6 to assemble an FLX bill of materials. It is recommended that some additional heating cable per circuit be allowed to compensate for variations between the existing drawings and the actual installation area.

Quantity	Description
_____	FLX 8-1 OJ or FLX 8-2 OJ Self-Regulating Heating Cable (refer to Table 3.0 on page 5 for proper cable type)
_____	TBX-3LC Power Connection Kit
_____	ET-6C End Termination Kit
_____	JB-K Nonmetallic Junction Box (for cable termination)
_____	CL “Electric Heat Tracing” Caution Labels (peel-and-stick labels attach to junction boxes, power distribution and control panel(s), or as required by code or specification)
_____	Adjustable Thermostat (not shown)
_____	RTD-500-3 Resistance Temperature Detector (for use with the HeatChek system)
_____	HeatChek Control and Monitoring System

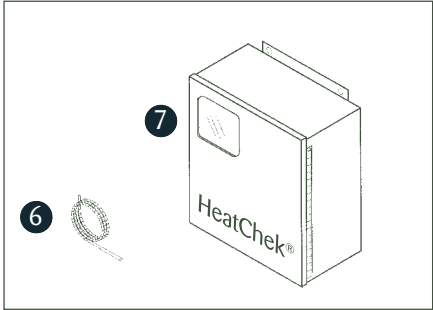
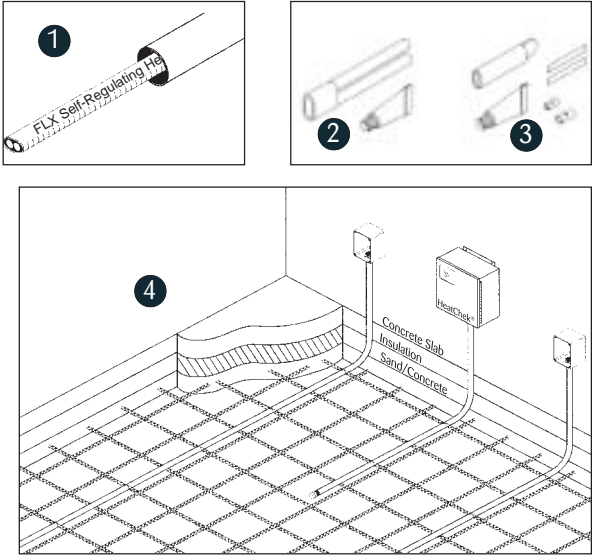

General Specification

Part 1 . . . General

Furnish and install a complete UL Listed system of heaters and components approved specifically for freezer floor frost heave protection. The heat tracing system shall conform to IEEE Standard 515.1-1995.

Part 2 . . . Products

1. The self-regulating heating cable shall be of parallel construction and shall consist of two nickel-plated copper bus wires embedded in a radiation cross-linked semiconductive polymer core. The heater shall include a tinned copper braid to provide grounding and polyolefin outer jacket for additional mechanical protection for the cable
2. The heater shall operate on line voltage of (select: 110-120, 208, 220, 240, 277 or 480) Vac without the use of transformers.
3. The heating cable shall be suitable for use with metallic and nonmetallic conduit.
4. Power connections and end seal terminations shall be made in junction/pull boxes as described under Part 5, Installation.
5. For additional energy conservation, the heating cable shall be controlled by (select):
 - a. An adjustable thermostat based on current loads for each circuit.
 - b. A resistance temperature detector (RTD) used in conjunction with a microprocessor-based temperature control and monitoring module. Control and monitoring shall be capable of switching up to 30 amps per circuit at 120/208/220/240/277 Vac.
 - c. When the load of the heating cable exceeds the rating of the temperature controller, the heating cable shall be controlled through an appropriately sized contactor.
6. All heating cable core will be permanently marked with the manufacturer's identification number for traceability.
7. Acceptable products and manufacturers are:
 - a. FLX™ 8 Self-Regulating heating cable and accessories as manufactured by Thermon Industries, Inc.
 - b. HeatChek® systems and components as manufactured by Thermon Industries, Inc.
8. Refer to the manufacturer's "Freezer Floor Frost Heave Protection Design Guide" for design details, insulation requirements, maximum circuit lengths and accessory information.

Part 3 . . . System Performance

1. Heating cable layout should be based on (select preferred design method):
 - a. Manufacturer's frost heave protection design guide.
 - b. Section 6.5, Frost Heave Prevention, of the IEEE Standard 515.1-1995, Recommended Practice for the Testing, Design, Installation, and Maintenance of Electrical Resistance Heat Tracing for Commercial Applications.

2. System performance shall be based on temperatures below the insulation barrier of 40°F (4°C) during freezer operation.

Part 4 . . . Manufacturer

1. The manufacturer shall demonstrate experience manufacturing and designing freezer floor frost heave protection systems with self-regulating heating cables. This experience may be documented with a list of ____ projects utilizing at least 500 feet (152 m) of self-regulating heating cable.
2. Manufacturer's Quality Assurance Program shall be certified to the ISO 9001 Standard.

Part 5 . . . Installation

1. Heating cable shall be installed in a minimum 3/4" conduit within the base layer of the substrate, approximately 2" (5 cm) below the insulation barrier.
2. Installer shall follow manufacturer's installation instructions and design guide for proper installation and layout methods. Deviations from these instructions could result in performance characteristics other than intended.
3. Power connections and end terminations shall be located in NEMA 4 junction boxes. Heating cable located between junction boxes and substrate shall be encased in conduit.
4. All installations and terminations must be made to conform to the NEC and any other applicable national or local code requirements.
5. Locate the RTD sensors as indicated on the system drawings.
6. Circuit breakers supplying power to the heat tracing must be equipped with a minimum of 30 mA ground-fault equipment protection (5 mA GFCI should not be used as nuisance tripping may result).
7. The electrician (see Division 16–Electrical) shall connect system to power.

Part 6 . . . Testing

1. Heating cable shall be tested with a 2,500 Vdc megohmmeter (megger) between the heating cable bus wires and the heating cable's metallic braid. While a 2,500 Vdc megger test is recommended, the minimum acceptable level for testing is 1,000 Vdc. This test should be performed a minimum of three times:
 - a. Prior to installation while the cable is still on reel(s).
 - b. After installation of heating cable and completion of power connection and end terminations.
 - c. Upon completion of concrete cap pour.
2. The minimum acceptable level for the megger readings is 20 megohms, regardless of the circuit length.
3. Results of the megger readings should be recorded and submitted to the construction manager.



ISO 9001
REGISTERED

Thermon . . . The Heat Tracing Specialists®
100 Thermon Drive • PO Box 609 • San Marcos, TX 78667-0609
Phone: 512-396-5801 • Facsimile: 512-754-2431 • **800-730-HEAT**
www.thermon.com