

# SnoTrace™ KSR™

Systems for Surface Snow and Ice Melting

**DESIGN GUIDE**



**The Heat Tracing Specialists®**

Commercial Products

## DESIGN GUIDE

### Contents

<b>Introduction</b> .....	<b>2</b>
<b>Application Information</b> .....	<b>2-5</b>
Product Description	
Characteristics	
Approvals	
System Components	
<b>Design Outline/Bill of Materials/Worksheet</b> .....	<b>6-7</b>
<b>Basis for a Good Design</b>	
Step 1: Identify Area Requiring Snow and Ice Melting .....	8
Step 2: Determine Level of Protection Required .....	9
Step 3: Select Voltage, Size Breakers, Calculate Electrical Load .....	10
Step 4: Locate Power Connections and End Terminations; Lay Out Cable .....	11-12
Step 5: Establish Control Method to Operate System .....	13
<b>General Specification</b> .....	<b>14-15</b>
<b>Appendix 1</b> .....	<b>16-17</b>

For additional information about the principles of electric heat tracing and how they apply to snow and ice melting, please review the SnoTrace brochure (Thermon Form CPD1010) and the KSR product specification sheet (Thermon Form CPD1056) or contact Thermon.

# SnoTrace™ KSR™ Systems for Surface Snow and Ice Melting

## Introduction . . .

Snow melting systems have been steadily increasing in popularity during the last few years. This is due in part to the risk management demands placed on building owners and occupants to provide clear and safe access to the facilities even during inclement weather. The intent of this guide is to simplify the design and installation of an electrical snow and ice melting system.

While there exists a multitude of methods for determining the heating requirements of a snow and ice melting system, the goal is to keep the protected area safe and accessible. The severity of weather in which the system must perform is of primary significance. Therefore, it is important to establish a performance level<sup>1</sup> as the amount of materials and power requirements are directly related to the weather conditions.

Establishing a proper sequence of design, procurement, installation and performance expectations before each function occurs will ensure successful installation of a heat tracing system. To facilitate this interaction, Thermon has assembled this design guide<sup>2</sup> to assist engineers and contractors.

## Why Heat Trace?

The reasons for installing an electric heat tracing snow and ice melting system are many. Some typical reasons include:

- Public safety—Keeping snow and ice from accumulating around building entrances, sidewalks and steps where safe pedestrian travel is required. Entrance or exit ramps to parking garages, hospital emergency entrances or similar areas are often a frequent wintertime concern in snow-belt areas.
- 24-hour access to the facility—Snow and ice seem to accumulate during the most inopportune times. Since a SnoTrace system can be controlled by an automatic snow and ice sensor, the system is activated as soon as precipitation starts to fall, regardless of the time of day or night.
- Difficulty with removing snow by plowing, shoveling or blowing—Oftentimes, the area is surrounded by buildings or other structures. This can present a challenge to maintenance crews trying to remove snow, especially after several accumulations have been piled in the few spaces available.
- Use of sand, salt or chemicals to melt snow and ice may be prohibited—To prevent ground water contamination, many areas are restricting the use of salt and other melting agents. The use of sand tends to create a cleanup problem when tracked into a facility. Salt or other chemicals can also pose a serious corrosion concern when used at or near facilities which rely on steel for structural support. Bridges, parking garages, elevated walkways or platforms all utilize large quantities of steel in their construction.

## Notes . . .

1. The examples and descriptions contained in this guide are based on structurally sound, steel-reinforced slab-on-grade concrete 4 to 6 inches thick. The amounts of heat provided in the design tables are for snow and ice melting at the rates indicated. Prevention of accumulation from drifting snow or runoff from other sources may require additional heating cable. Should design conditions vary from those shown, please contact a Thermon factory representative for assistance.
2. The formulas, calculations, charts, tables and layout information presented have been researched for accuracy; however, the design and selection of a snow and ice melting system are ultimately the responsibility of the user.



The Heat Tracing Specialists®

## Product Description . . .

SnoTrace KSR is a high performance, durable, self-regulating heating cable designed specifically for snow and ice melting. The parallel resistance construction allows the cable to be cut-to-length and terminated in the field. The self-regulating feature of KSR varies the heat output in response to the surroundings. When the concrete is at or below freezing temperatures, KSR will deliver the maximum power output. As the concrete warms-up, the power output of the cable will decrease. Energy efficiency can be accomplished without special or sophisticated controls.

To ensure long life and protection during cable installation, a tinned copper braid and an overall outer silicone rubber jacket further protect the cable. For easy installation KSR utilizes cut-to-length circuitry. This feature minimizes the need to re-design circuits when changes are encountered at the jobsite. Circuit fabrication and splice kits developed specifically for KSR allow ease of termination with ordinary hand tools.

## Characteristics . . .

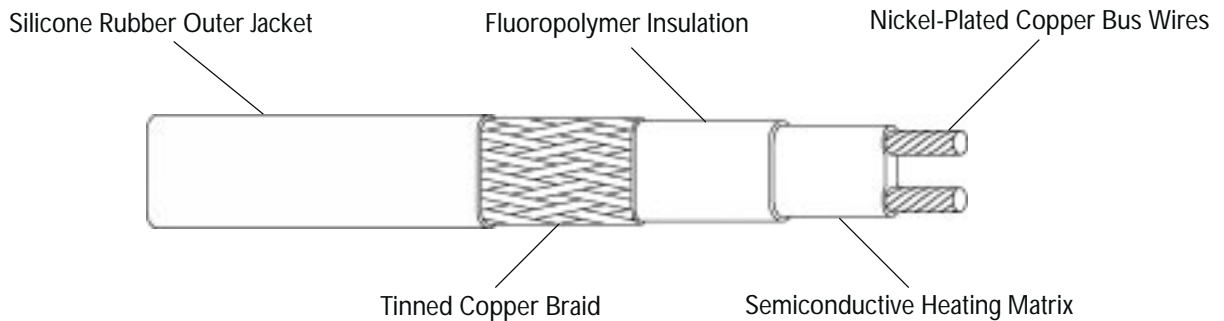

Bus wire .....	16 AWG nickel-plated copper
Heating core .....	semiconductive heating matrix
Primary dielectric insulation .....	high performance fluoropolymer
Metallic braid .....	tinned copper (0.00328 ohms per foot)
Outer jacket .....	silicone rubber
Minimum bend radius .....	1.25" (32 mm)
Supply voltage .....	208-277 Vac
Circuit protection <sup>1</sup> .....	30 mA ground-fault protection required

### Note . . .

1. Ground-fault equipment protection (30 mA or greater) is required for all snow and ice melting heat tracing circuits per the National Electric Code Article 426-53.

# SnoTrace™ KSR™ Systems for Surface Snow and Ice Melting

## Product Approvals . . . Tests . . . Compliances . . .

Thermon's SnoTrace KSR carries the following major agency approval:



**Underwriters Laboratories Inc.**  
5N23 De-Icing and Snow-Melting  
Equipment (KOBQ).

KSR has been certified to IEEE Standard 515.1-1995, Recommended Practice for the Testing, Design, Installation, and Maintenance of Electrical Resistance Heat Tracing for Commercial Applications.

## KSR Cables Meet or Exceed the Following Requirements . . .

Test	Standard Followed
Water Resistance Test .....	IEEE 515.1 (4.2.2)
Cold Impact .....	IEEE 515.1 (4.2.9)
Cold Bend .....	IEEE 515.1 (4.2.10)
Deformation .....	IEEE 515.1 (4.2.8)
Flammability .....	IEEE 515.1 (4.2.7)
Resistance to Cutting .....	IEEE 515.1 (4.3.3)
Resistance to Crushing .....	IEEE 515.1 (4.4.2)
Thermal Stability .....	IEEE 515.1 (4.2.6)

## System Components . . .

A SnoTrace KSR snow and ice melting system will typically include the following components:

1. **KSR** self-regulating heating cable (refer to cable selection chart on page 10 for proper cable).
2. **KSR-CFK** circuit fabrication kit prepares heating cable for end termination and connection to power.
3. **KSR-JB** NEMA 4X nonmetallic junction box permits two to four cables to be terminated.
4. **KSR-EJK** expansion joint kit.
5. **KSR-SK-DB** cable splice kit (not shown) permits cable to be spliced.
6. **NT-7** nylon tie wraps secure cable to reinforcing steel (250 per bag).
7. **CL-1** "Electric Heat Tracing" labels peel and stick to junction boxes, power distribution and control panel(s), or as required by code or specification.



The Heat Tracing Specialists®

# DESIGN GUIDE

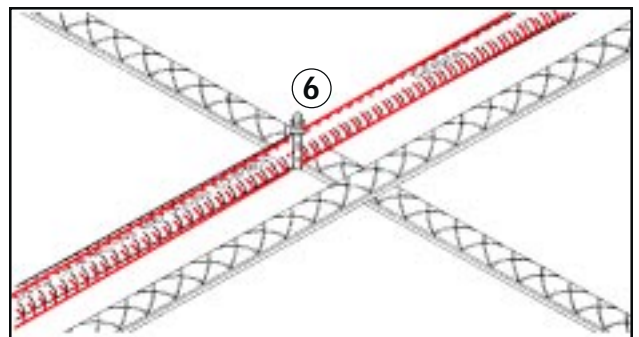
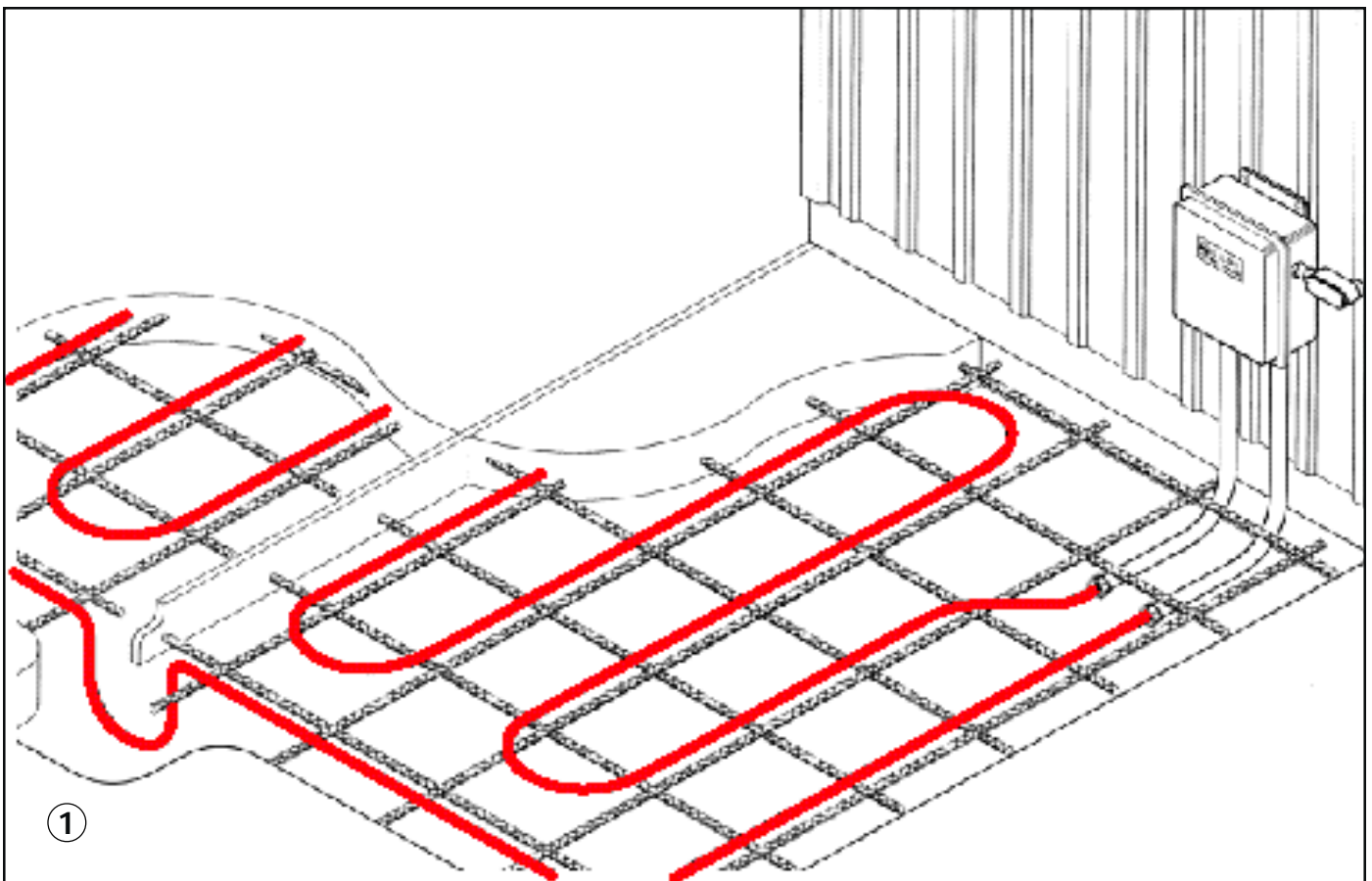
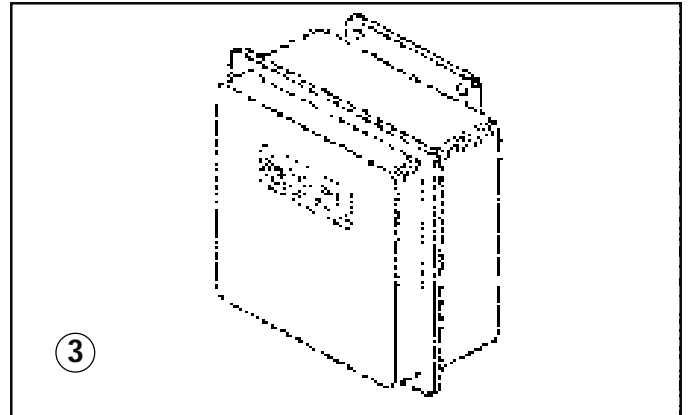
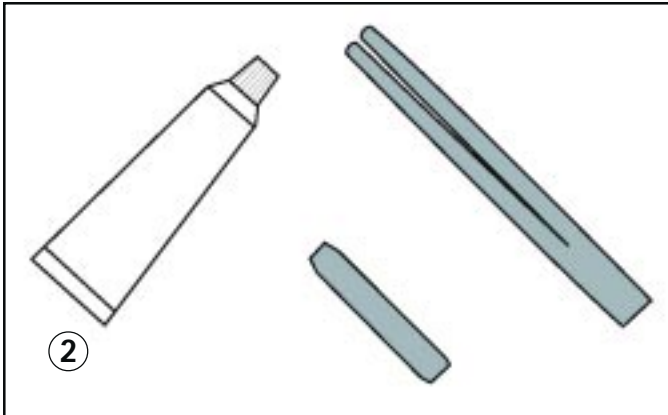

# SnoTrace™ KSR™ Systems for Surface Snow and Ice Melting

## SnoTrace KSR Design Outline . . .

The following steps outline the design and selection process for an KSR snow melting system:

### Step 1: Identify the Area Requiring Snow and Ice Melting

### Step 2: Determine Level of Protection Required

Based on:

- a. Expected rate of snowfall
- b. ASHRAE percentage of snowfall hours surface remains clear

### Step 3: Establish Voltage/Breaker/Power Requirements

- a. Select Operating Voltage
  - 208-240 Vac = KSR 2-OJ
  - 277 Vac = KSR 3-OJ
  - Other voltages

#### b. Size Circuit Breakers

Based on:

- Available breakers in general power distribution equipment
- Expected KSR circuit lengths (see Table 3.1)
- Maximum circuit length for voltage and amperage combination

#### c. Determine Power Requirements

- Estimate the total footage of KSR required
- Calculate the kilowatt load of a system

### Step 4: Specify the Locations for Power Connections/End Terminations; Lay Out Cable

- a. Junction boxes
- b. KSR layout
- c. Expansion joints
- d. Stair steps

### Step 5: Establish Control Method Needed to Operate System

- a. Manual
- b. Automatic
  - Ambient sensing thermostat
  - Snow and ice sensor/controller

The KSR Design Guide Worksheet at right and the step-by-step procedures which follow will provide the reader with the detailed information required to design and specify a fully functional snow and ice melting system.

## SnoTrace Bill of Materials . . .

Use the design outline steps at left and detailed steps on the following pages to assemble an KSR bill of materials. It is recommended that some additional heating cable be allowed to compensate for variations which might exist between the drawings and the actual installation area.

Quantity	Description
_____	<b>KSR</b> Self-Regulating Heating Cable (refer to Table 3.1 on page 10 for proper cable)
_____	<b>KSR-CFK</b> Circuit Fabrication Kit (for end termination and connection to power; 1 kit needed per circuit)
_____	<b>KSR-JB</b> NEMA 4X Nonmetallic Junction Box (permits 2 to 4 cable ends to be terminated)
_____	<b>KSR-EJK</b> Expansion Joint Kit
_____	<b>KSR-SK-DB</b> Cable Splice Kit
_____	<b>NT-7</b> Nylon Tie Wraps (secure cable to reinforcing steel; 250 per bag)
_____	<b>CL-1</b> "Electric Heat Tracing" Labels (peel-and-stick labels attach to junction boxes, power distribution and control panel(s), or as required by code or specification)
_____	<b>STC-DS-2B</b> Snow Sensor



The Heat Tracing Specialists®





# SnoTrace™ KSR™ Systems for Surface Snow and Ice Melting

## Basis for a Good Design . . .

The following five design steps provide a detailed description of the outline shown on page 6.

An example following each design step will take the reader through the process of evaluating, designing and specifying a snow melting system.

While the example shown is small, the process would be the same regardless of the area to be protected. The design example includes flat surfaces, stairs, a ramp, expansion joints in the concrete and the need to bring power from a specific location.

### Step 1: Identify the Area Requiring Snow and Ice Melting

Determining the area that will require heat tracing is based somewhat on the traffic expected during snow and ice accumulation periods plus the layout of the area and its location relevant to prevailing winds and susceptibility to drifting.

Ensure that the area to receive snow and ice melting will be structurally sound. This includes identifying the existence of electric snow and ice melting heat tracing cable in the *Concrete Curbs, Walks and Paving* (Division 2) portions of the project specification. In addition, the project drawings (both electrical and site work) should include reference to the existence of electric heat tracing.

**Example . . .** The public/employee entrance to a facility is exposed to weather with only the area directly in front of the entry doors covered by a roof. The building is adjacent to the concrete on two sides with the handicap access ramp (which has a retaining wall) located on the third side. Snow removal could only be accomplished at the curb and parking area, a choice found undesirable for various reasons.

To maintain a clear entrance, the landing, stairs, ramp and approach area will require snow melting. The area in front of the doors will be heat traced to prevent accumulation from drifting and tracking.

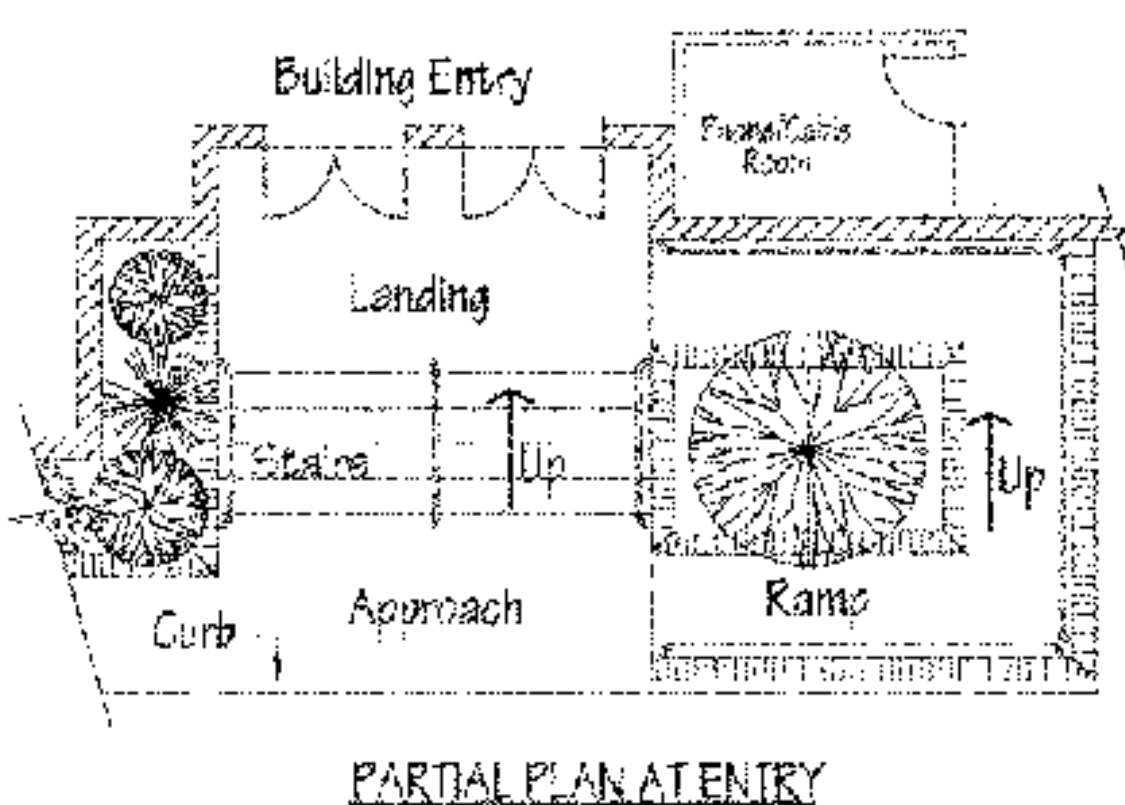

Figure 1.1



The Heat Tracing Specialists®

## Step 2: Determine the Level of Protection Required

Regardless of geographical location or size of area to be protected, the heating requirements for snow melting are affected by four primary factors:

- Rate of snowfall
- Ambient temperature
- Wind velocity
- Humidity

Establishing the level of protection required for a facility requires an understanding of the type of service the area will encounter and under what type of weather conditions the snow and ice melting system must perform<sup>1</sup>. Thermon developed Table 2.1 SnoTrace KSR Cable Spacing (using information from IEEE Standard 515.1-1995 and ASHRAE) to simplify the selection process for determining the level of protection required. An additional design table can be found in the appendix. This table, compiled from information found in Chapter 45 (Snow Melting) of the ASHRAE Applications Handbook, gives level of protection (percentage of snowfall hours surface is clear) and KSR heating cable spacing recommendations for specific cities.

When an application requires an in-depth design review or does not conform to the “standard” design conditions stated, contact Thermon or a Thermon factory representative for additional design information. Thermon can provide a complete snow and ice melting review using finite element analysis (FEA) plus other computer-aided design programs to accurately assess your application.

**Example . . .** Since the example shown is a public/employee entrance it would be considered a noncritical area (from the KSR cable spacing chart for snow melting) where snow removal is convenient but not essential. Additionally, the example is located in Ann Arbor, Michigan, where the snowfall severity would fall into the “moderate” category of 1” per hour. Based on this information, the heating cable should be installed on 9” center-to-center spacing. If the design was to meet ASHRAE requirements, refer to Appendix 1. Since Ann Arbor is not included in the list, the data for Detroit is used. Referring to Table 1 for Detroit, 9” center-to-center spacing of KSR cable indicates that for approximately 97% of snowfall hours the surface will remain clear.

**Table 2.1 SnoTrace KSR Cable Spacing<sup>2</sup>**

Snowfall Severity Category	Rate of Snowfall	KSR Cable Spacing	
		Noncritical	Critical
Light	½”/hour	12” O.C.	7½” O.C.
Moderate	1”/hour	9” O.C.	6” O.C.
Heavy	2”/hour	7½” O.C.	5” O.C.

**Noncritical:** Applications where snow removal is a convenience but not essential. Examples include building entrances, loading docks and parking garage ramps.

**Critical:** Applications where safe access is essential. Examples include hospital emergency entrances, train loading platforms and fire station driveways.

**Notes . . .**

1. Additional heat may be needed if the area will be subject to drifting or moisture runoff from another source. No allowance has been made for back or edge loss. Both back and edge loss will occur to varying degrees on every application. The amount and extent of loss is affected by soil types, frost line depth, shape and size of the area, plus the location of the area as it relates to other structures and wind.
2. Spacing as shown in Table 2.1 will provide a completely melted surface for the concrete area under typical snowfall weather conditions—ambient temperatures between 20°F and 34°F with wind speeds of 5 to 15 mph. Should the ambient temperature fall below 20°F during the snowstorm, some snow accumulation could occur but will be melted at the rate of fall.

# SnoTrace™ KSR™ Systems for Surface Snow and Ice Melting

## Step 3: Select Operating Voltage, Size Circuit Breakers and Determine Power Requirements

Most snow melting applications will utilize a 208, 220, 240 or 277 Vac power supply. To ensure maximum snow melting potential, KSR is provided in two standard versions<sup>1</sup>. Table 3.1, Cable Selection, shows the circuit lengths possible with KSR heating cable at each voltage. For a specific system, match the branch circuit breaker size to the KSR circuit length based on:

- The maximum circuit length shown in Table 3.1 or
- The maximum circuit length required for a given heating cable layout or
- The maximum circuit length for a predetermined branch circuit breaker size.

Estimating the amount of KSR heating cable required, number of circuits needed and the total power requirements can be accomplished with Formulas 3.1 and 3.2. These estimates will be useful for coordinating the material and power requirements for the system.

### Formula 3.1 Estimating Quantity of KSR Required<sup>2</sup>

$$\text{Total KSR cable required} = \text{Area in square feet} \times (12 \div S)$$

Where: S = KSR cable spacing in inches

Dividing the total KSR cable estimate by the circuit length shown in Table 3.1 will give an indication as to how many circuits will be needed for a given branch circuit breaker size.

The total operating load of a KSR snow and ice melting system is dependent on the supply voltage and the total footage of cable which will be energized. To determine the total operating load, use the following amps per foot multipliers:

**KSR-2 @ 208-240 Vac draws 0.12 amps/foot**

**KSR-3 @ 277 Vac draws 0.10 amps/foot**

By inserting the appropriate values into the following formula, the total load of the snow and ice melting system can be determined.

### Formula 3.2 Total Heat Output/Operating Load

$$P_t = L_t \times I_f \times E$$

Where:  $P_t$  = Total heat output (in watts) for system

$L_t$  = Total installed length of KSR heating cable

$I_f$  = Amps per foot multiplier for voltage used

$E$  = Operating voltage

**Table 3.1 Cable Selection**

Catalog Number	Start-Up Temperature	Operating Voltage	Installation Method	Maximum Circuit Length vs. Breaker Size			
				15 Amp	20 Amp	30 Amp	40 Amp
KSR-2	0°F (-18°C)	208 Vac	Direct Burial	80' (24 m)	105' (32 m)	160' (49 m)	210' (64 m)
KSR-2	0°F (-18°C)	220 Vac	Direct Burial	80' (24 m)	105' (32 m)	165' (50 m)	215' (66 m)
KSR-2	0°F (-18°C)	240 Vac	Direct Burial	85' (26 m)	110' (34 m)	170' (52 m)	225' (69 m)
KSR-3	0°F (-18°C)	277 Vac	Direct Burial	100' (30 m)	135' (41 m)	205' (62 m)	270' (82 m)
KSR-2	20°F (-7°C)	208 Vac	Direct Burial	85' (26 m)	110' (34 m)	165' (50 m)	220' (67 m)
KSR-2	20°F (-7°C)	220 Vac	Direct Burial	85' (26 m)	110' (34 m)	170' (52 m)	225' (69 m)
KSR-2	20°F (-7°C)	240 Vac	Direct Burial	90' (27 m)	120' (37 m)	180' (55 m)	225' (69 m)
KSR-3	20°F (-7°C)	277 Vac	Direct Burial	110' (34 m)	150' (46 m)	225' (69 m)	270' (82 m)

**Example . . .** As the example facility will have 277 Vac, three-phase, four-wire available, KSR-3 cable is selected. To optimize the circuit length potential, the branch circuit breakers will be sized to reflect the layout of the cable (see Step 4 for cable layout).

Using Formula 3.1 . . .

$$\text{Total KSR cable required} = \text{Area in ft}^2 \times (12 \div S)$$

and substituting values for the design example . . .

$$\text{Total KSR cable required} = 600 \text{ ft}^2 \times (12 \div 9)$$

the total footage of cable can be estimated . . .

$$\text{Total KSR cable required} = 800 \text{ linear feet}$$

(plus allowance from Note 2)

Using Formula 3.2 . . .

$$P_t = L_t \times I_f \times E$$

and substituting values for the design example . . .

$$P_t = 840 \text{ ft} \times 0.10 \text{ amps/ft} \times 277 \text{ Vac}$$

the total kilowatt demand for the system can be estimated . . .

$$P_t = 23,268 \text{ watts or } 23.3 \text{ kw}$$

Notes . . .

1. Should these voltages not be available, contact a Thermon factory representative or Thermon for design assistance.
2. When calculating the amount of KSR heating cable required based on the square footage of the area, allowances should be included for making connections within junction boxes and for any expansion joint kits necessary to complete the layout.



The Heat Tracing Specialists®

## Step 4: Specify Locations for Power Connections/End Terminations and Lay Out Cable on Scaled Drawing

**Junction Boxes** . . . KSR power connection and end termination points must be located inside suitable junction boxes located above the moisture line. Depending on the size of the junction box, several power connections and/or end terminations can be located within the same box.

- Protect heating cable with rigid metallic conduit (one cable per conduit) between junction box and area being heated.
- Extend conduit (equipped with bushings on each end) a minimum of 12" into slab.

A typical junction box and conduit assembly is shown in Figure 4.1.

**KSR Layout** . . . When the location of the junction boxes for power connections and end terminations has been established, lay out the heating cable.

- Use a scaled drawing or sketch to simplify the process.
- Base layout on center-to-center spacing selected in Step 2.
- Do not exceed circuit lengths shown in Table 3.1.
- Locate cable 2" to 4" below finished concrete surface.
- For standard slab (4" to 6" thick), place KSR directly on top of reinforcing steel.
- Attach to steel with nylon tie wraps on 24" (minimum) intervals.

**Expansion Joints** . . . Unless the slab is of monolithic construction, there will be expansion or construction joints which must be taken into account to prevent damage to the cable.

- Keep expansion joint kit use to a minimum by utilizing proper layout techniques.
- Mark drawings with locations of expansion and construction joints.
- Allow an extra 3' of KSR for each expansion joint kit.

**Stair Steps** . . . Because of the rugged yet flexible nature of KSR and the center-to-center spacing typical to most applications, difficult areas such as steps can be easily accommodated.

- Tie KSR to reinforcing steel in same manner as open areas.
- Serpentine across each tread; route up riser to next tread.
- Concrete can be placed in single pour.

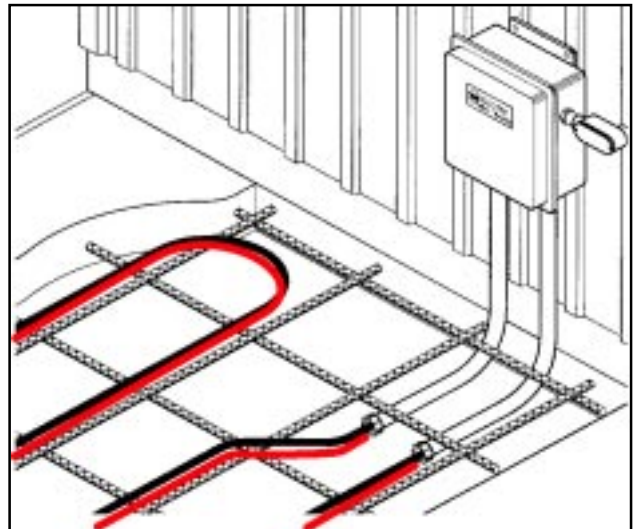

Figure 4.1 Junction Box/Conduit

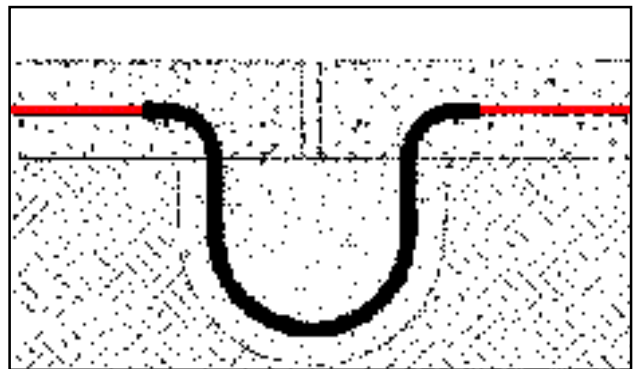

Figure 4.2 Expansion Joint Kit Section

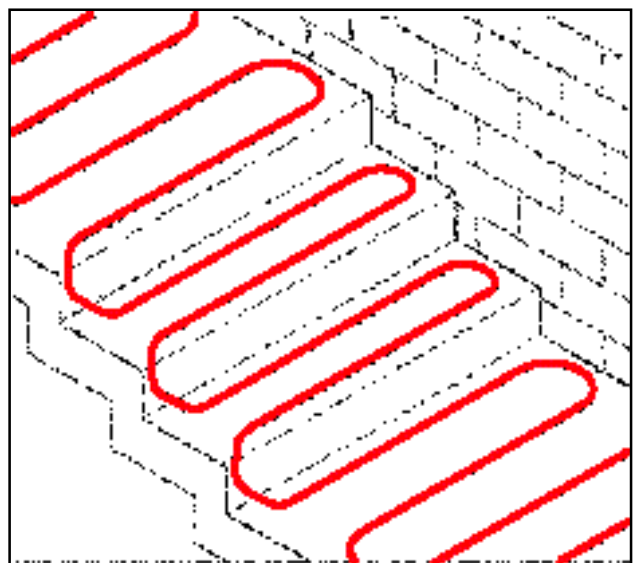

Figure 4.3 Detail at Steps

# SnoTrace™ KSR™ Systems for Surface Snow and Ice Melting

## Step 4: Specify Locations for Power Connections/End Terminations and Lay Out Cable on Scaled Drawing (cont'd.)

**Example . . .** Determine a suitable location for the power connection and end termination junction boxes. Considerations should be given to aesthetics, obstructions, routing of power supply wiring and the space required for the junction boxes.

Several locations could be utilized in the example shown. These include either side of the entrance doors, the building wall where it meets the planter or the wall along the handicap access ramp.

The area located to the right of the entrance doors was ultimately selected because the room located behind it would make an excellent location for the snow melting power distribution and control panel.

When finished, the system layout will be as shown at right in Figure 4.5. Note how the heating cable has been routed to minimize the number of crossings at expansion joints. Additionally, all power connections and end terminations originate from the same area. This minimizes the power feed requirements and provides a clean installation. The layout shows that three circuits are required to cover the area based on the spacing selected. Since each of the three circuits is less than the 40-amp branch circuit breaker limit of 270 feet (refer to Table 3.1), power distribution can be accomplished through three 40-amp breakers with 30 mA ground-fault protection.

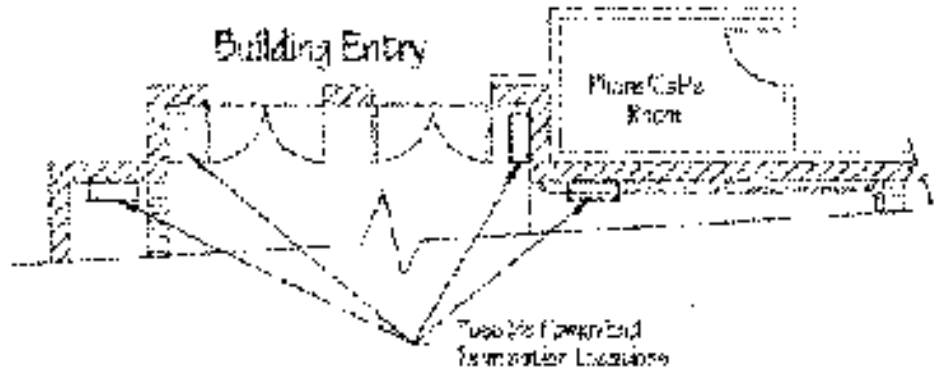

Figure 4.4

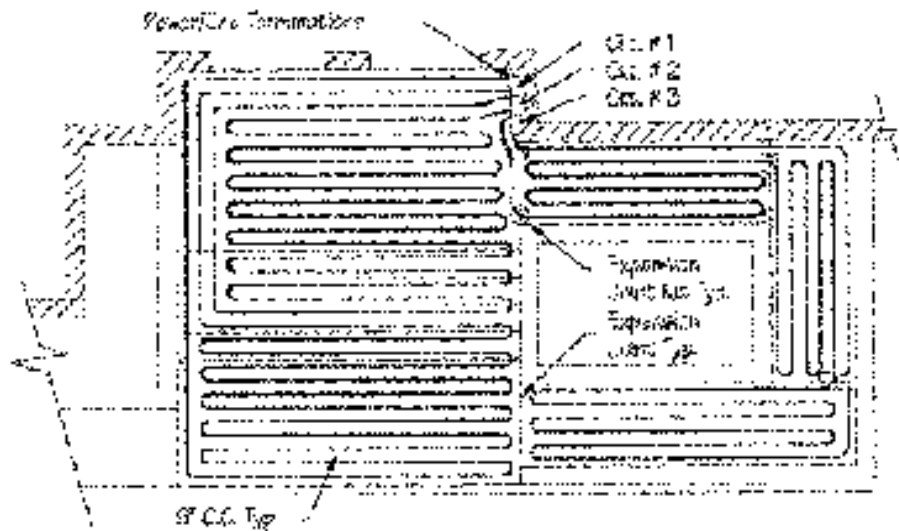

Figure 4.5





## Step 5: Establish Control Method Needed to Operate the System

**Energizing the Heating Cable . . .** All snow melting systems should be controlled to turn the heating cable on and off as conditions warrant. There are three basic means to activate a snow melting system:

### A. Manual

- On/Off Switch—Simple to install and economical to purchase; requires diligence on the part of the operator.

### B. Automatic

- Ambient Sensing Control—Turns system on and off based on ambient temperature. Heating cable will frequently be energized during nonrequired times.
- Automatic Control—Turns system on when precipitation is detected and temperatures are in the range where snow or freezing rain is likely.

Some applications, such as truck scales and loading zones, are subject to freezing water or slush accumulation even though no precipitation is falling. To properly deal with these conditions, a custom designed control system is typically required and the designer should contact Thermon for assistance.

**Example . . .** Because the facility will be occupied during normal weekday business hours, the system is to be controlled automatically. To accomplish this, an STC-DS-2B snow and ice sensor will be utilized.

A power distribution and contactor panel would consist of a main 3-pole breaker, a 3-pole contactor and three 40-amp branch circuit breakers equipped with 30 mA ground-fault protection. The panel would also be equipped with a hand/off/auto switch plus lights to indicate system status.

Because the panel will be located indoors, a NEMA 12 enclosure is suitable for the panel. If the panel was to be installed outside, a NEMA 4 or 4X enclosure would be required.

**Providing Power Distribution and Contactors . . .** When a snow melting system requires four or more heat tracing circuits, it is recommended that a dedicated power distribution and contactor panel be utilized. By keeping the snow melting circuit breakers in a dedicated panel, several design and operation advantages will occur:

- The panel can utilize a main circuit breaker and contactor which permits a complete shutdown of the system for out-of-season times as well as routine maintenance checks.
- A dedicated snow melting panel will reduce the potential of non-authorized access.
- A dedicated snow melting panel can be located close to the point of use and reduce power feed wiring and conduit necessary to energize the system.
- In critical snow melting applications, the panel can be equipped with a monitor and alarm feature that will verify the integrity of the circuit and the status of the ground-fault branch circuit breakers.

# General Specification

## Part 1 . . . General

Furnish and install a complete UL Listed system of heaters and components approved specifically for snow and ice melting. Heating cable must be suitable for direct burial in concrete or asphalt. The heat tracing system shall conform to ANSI/IEEE and IEEE Standard 515.1-1995. Compliance with manufacturer's installation instructions in its entirety is required.

## Part 2 . . . Products

1. The heating cable and termination components shall be UL Listed specifically as electric de-icing and snow-melting equipment.
2. The heating cable shall be of parallel resistance construction capable of being cut to length and terminated in the field.
3. The cable shall provide the heat necessary to melt snow and ice through a semi-conductive polymer heating matrix. The heater shall be covered by a fluoropolymer dielectric jacket, a tinned copper braid for grounding purposes and an overall silicone outer jacket for added protection during installation.
4. The heating cable must reduce power output at elevated temperatures to prevent overheating and system damage if accidentally energized during periods above 40°F.
5. The heater shall operate on a line voltage of (select: 208, 220, 240 or 277) Vac without the use of transformers. Voltage rating of the dielectric insulation shall be 600 Vac.
6. Power connections and end seal terminations shall be made in junction boxes as described under Part 6, Installation.
7. Quality assurance test certificates are to accompany each reel of heating cable signed by the manufacturer's Quality Control Officer. Certificates are to indicate cable type, cable rating, voltage rating, test date, batch number, reel number and length of cable, test voltage and test amperage reading.
8. Acceptable products and manufacturers are:

- a. SnoTrace™ KSR™ as manufactured by Thermon Manufacturing Company.

9. Refer to the manufacturer's "Snow Melting Design Guide" for design details, installation requirements, maximum circuit lengths and accessory information.

## Part 3 . . . Power Distribution and Control

1. Systems with four or more circuits shall utilize a dedicated power distribution and contactor panel provided by the snow melting system manufacturer. Included in each panel will be a main breaker, contactor and 30 mA ground-fault branch circuit breakers. The panel enclosure will be rated for NEMA (select: 12 for indoors or 4 for outdoors) service. All panel components shall be UL and/or CSA certified.
2. Power to the snow melting circuits will be controlled by (select: a manual switch, an ambient sensing thermostat, or an automatic snow sensor) designed to control the heating cable load or the coil(s) of a contactor.

## Part 4 . . . System Performance

1. Heating cable spacing shall be based on (select preferred design method):
  - a. Manufacturer's snow melting design guide for a (select: noncritical or critical area) with (select: light, moderate, or heavy) snowfall level.
  - b. Chapter 45 (Snow Melting) of the ASHRAE Applications Handbook utilizing data for the city of \_\_\_\_\_ . Design shall meet the (insert percentage) level of clear surface under normal snowfall conditions per Table 1.
  - c. Section 6.3, Snow Melting, of the IEEE Standard 515.1-1995 Recommended Practice for the Testing, Design, Installation, and Maintenance of Electrical Resistance Heat Tracing for Commercial Applications.
  - d. Manufacturer to submit thermal analysis depicting the surface temperature based on \_\_\_ ambient temperature and \_\_\_ mph winds.
2. System performance shall be based on heated surface temperatures of 32°F (minimum) during the snow melting process. Start-up in cold concrete shall be used for circuit breaker sizing only.



The Heat Tracing Specialists®

# Snow and Ice Melting Electric Heat Tracing

## Part 5 . . . **Manufacturer**

1. The manufacturer shall demonstrate experience designing and engineering snow and ice melting systems. This experience may be documented with a list of \_\_\_ engineered projects with a minimum 500 square feet of heat-traced area.
2. Manufacturer's Quality Assurance Program shall be certified to the ISO 9001 Standard.

## Part 6 . . . **Installation**

1. Heating cable shall be installed directly in concrete within 2" to 4" of the finished surface (in asphalt 1½" to 2").
2. Installer shall follow manufacturer's installation instructions and design guide for proper installation and layout methods.
3. Power connections and end terminations shall be located in NEMA 4 or 4X junction boxes (Thermon KSR-JB or UL Listed equivalent). Heating cable located between the junction boxes and concrete shall be encased in rigid metal conduit (with protective bushings at each end) which extends 12" into the concrete.
4. Contractor shall provide and install rigid conduit, fittings, and power wiring from transformer to the circuit breaker panel to the heating circuit power termination boxes and from the automatic controller to the circuit breaker panel. Locate the automatic snow detector sensor as indicated on systems drawings provided by the manufacturer.
5. All installations and terminations must conform to the National Electrical Code and any other applicable national or local code requirements.
6. Circuit breakers supplying power to the heat tracing must be equipped with 30 mA minimum ground-fault equipment protection (5 mA GFCI should not be used as nuisance tripping may result).

## Part 7 . . . **Testing**

1. Heating cable shall be tested with a 2,500 Vdc megohmmeter (megger) between the heating cable bus wires and the heating cable metallic braid. While a 2,500 Vdc megger test is recommended, the minimum acceptable level for testing is 1,000 Vdc. This test should be performed a minimum of four times:
  - a. Prior to installation while the cable is still on reel(s).
  - b. After installation of heating cable and completion of circuit fabrication kits but prior to concrete or asphalt placement.
  - c. During the placement of concrete or asphalt.
  - d. Upon completion of concrete or asphalt placement.
2. The minimum acceptable level for the megger readings is 20 megohms, regardless of the circuit length.
3. Test should be witnessed by the construction manager for the project and the heating cable manufacturer or authorized representative. Results of the megger readings should be recorded and submitted to the construction manager.



# SnoTrace™ KSR™ Systems for Surface Snow and Ice Melting

## Appendix 1 . . .

As an alternate to the KSR cable spacing selection chart shown in Step 2, a snow and ice melting system can be designed using the information presented in Chapter 45 of the ASHRAE Applications Handbook. In their tutorial on snow and ice melting, ASHRAE compiled a list of 33 cities with weather data for each. Using this information, Thermon developed the table below to show the effect of various power (heat) outputs.

The values presented in Table 1, *Data for Determining Operating Characteristics of Snow Melting Systems* (ASHRAE 1991 Applications Handbook, Chapter 45), and detailed below show the calculated percentage of snowfall hours that a surface will

remain clear of snow when a predetermined level of heat is installed. This method is very useful when comparing what additional benefit, in terms of keeping an area clear, is obtained when the watts/ft<sup>2</sup> is increased.

While it is necessary to have weather data to establish values for temperature, wind, humidity and snowfall, ASHRAE cautions that a snow melting system should not be designed based on the annual averages or worst weather conditions encountered. Doing so will result in a system unnecessarily oversized for a majority of applications.

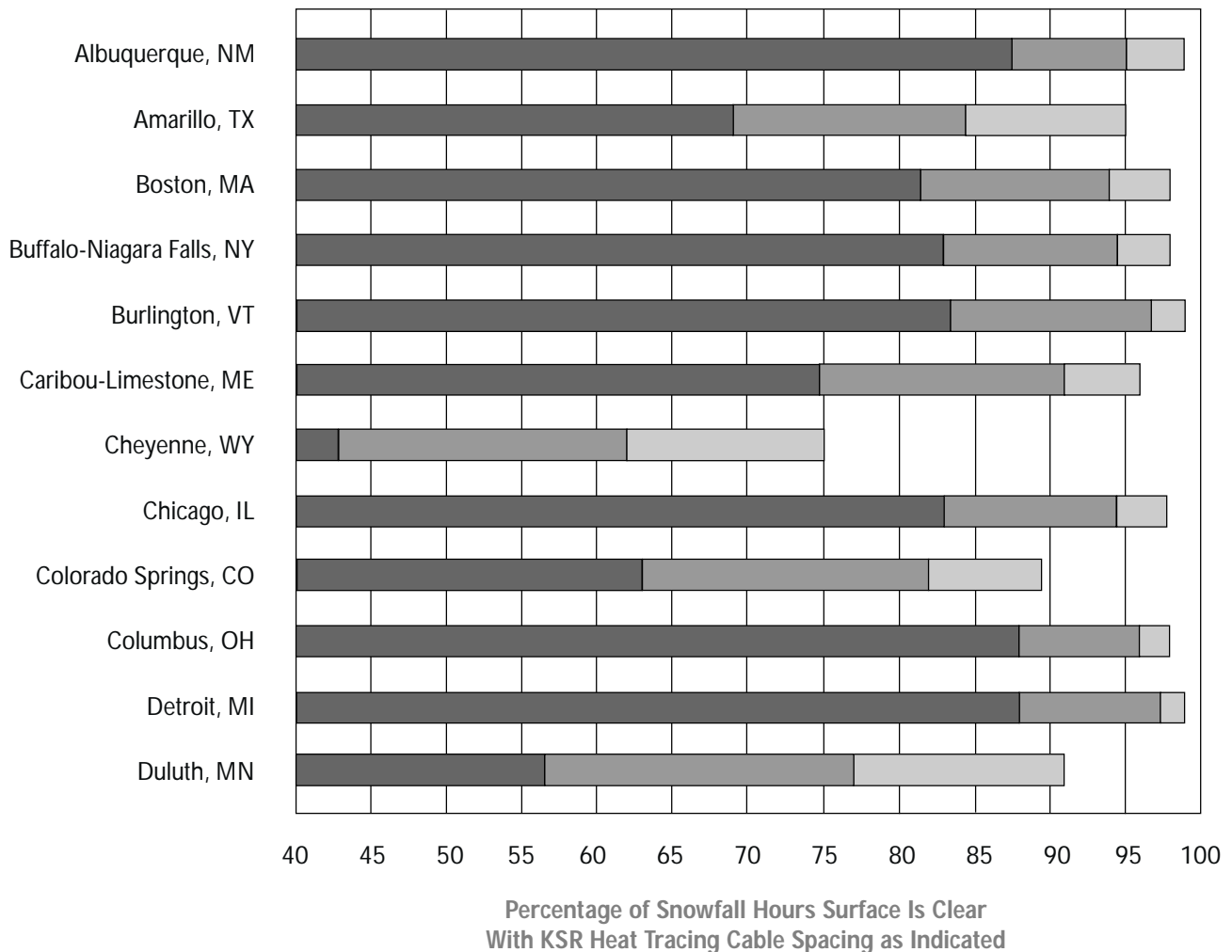

The Heat Tracing Specialists®

# CABLE SPACING SELECTION GUIDE

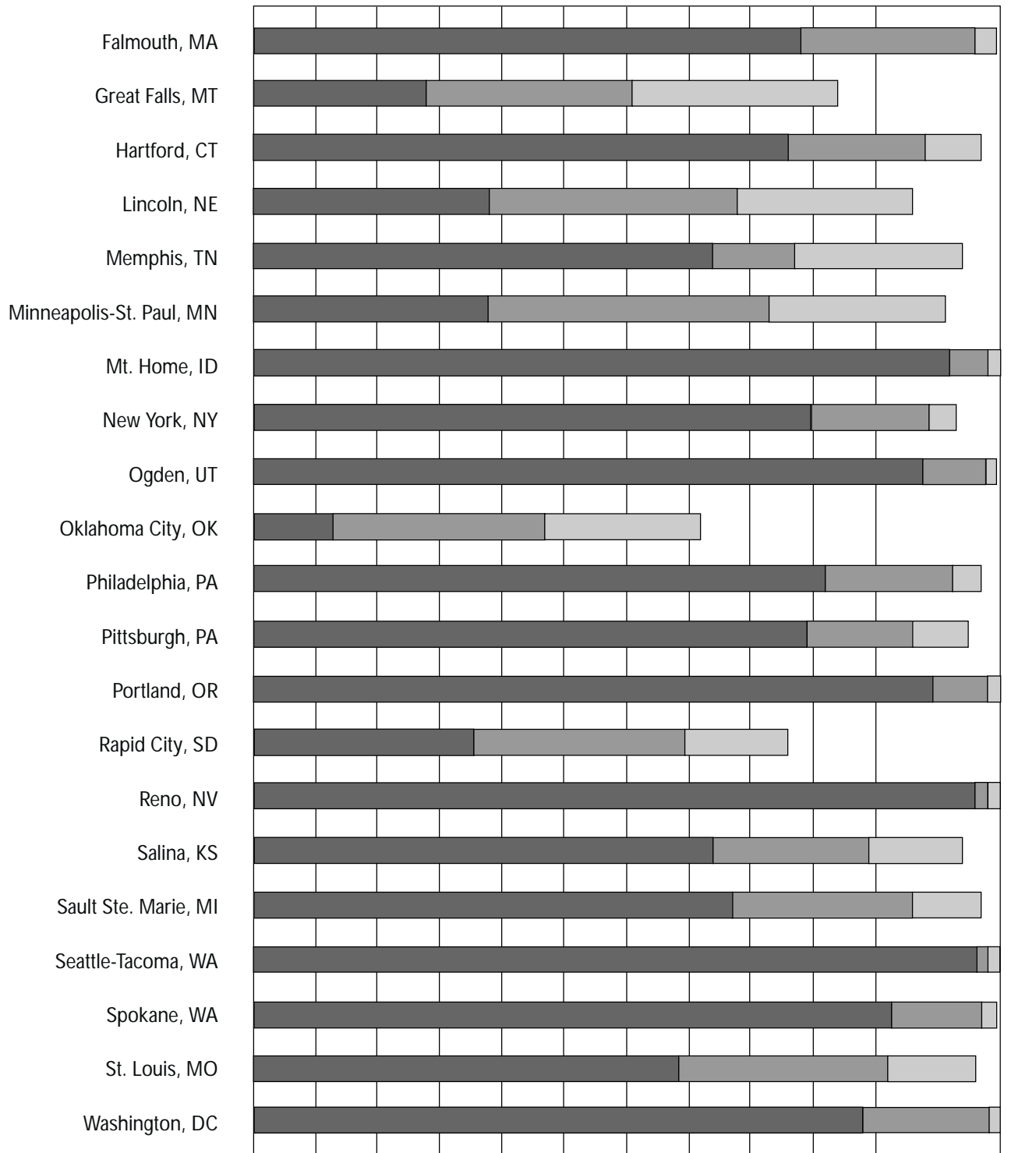

40 45 50 55 60 65 70 75 80 85 90 95 100

Percentage of Snowfall Hours Surface Is Clear  
With KSR Heat Tracing Cable Spacing as Indicated

6" O.C.
  9" O.C.
  12" O.C.

# SnoTrace™ KSR™ Systems for Surface Snow and Ice Melting

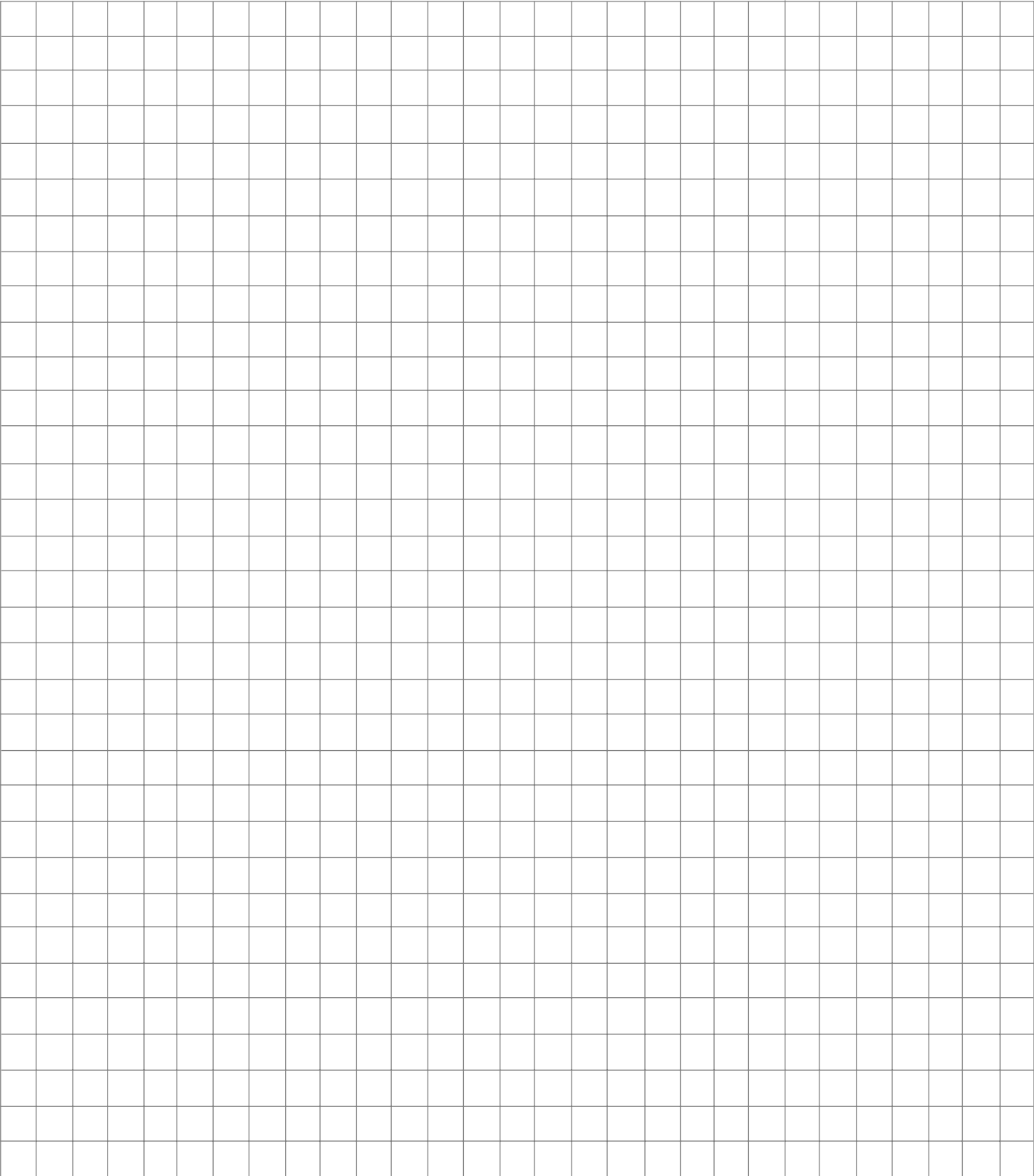

The Heat Tracing Specialists®

# WORKSHEET

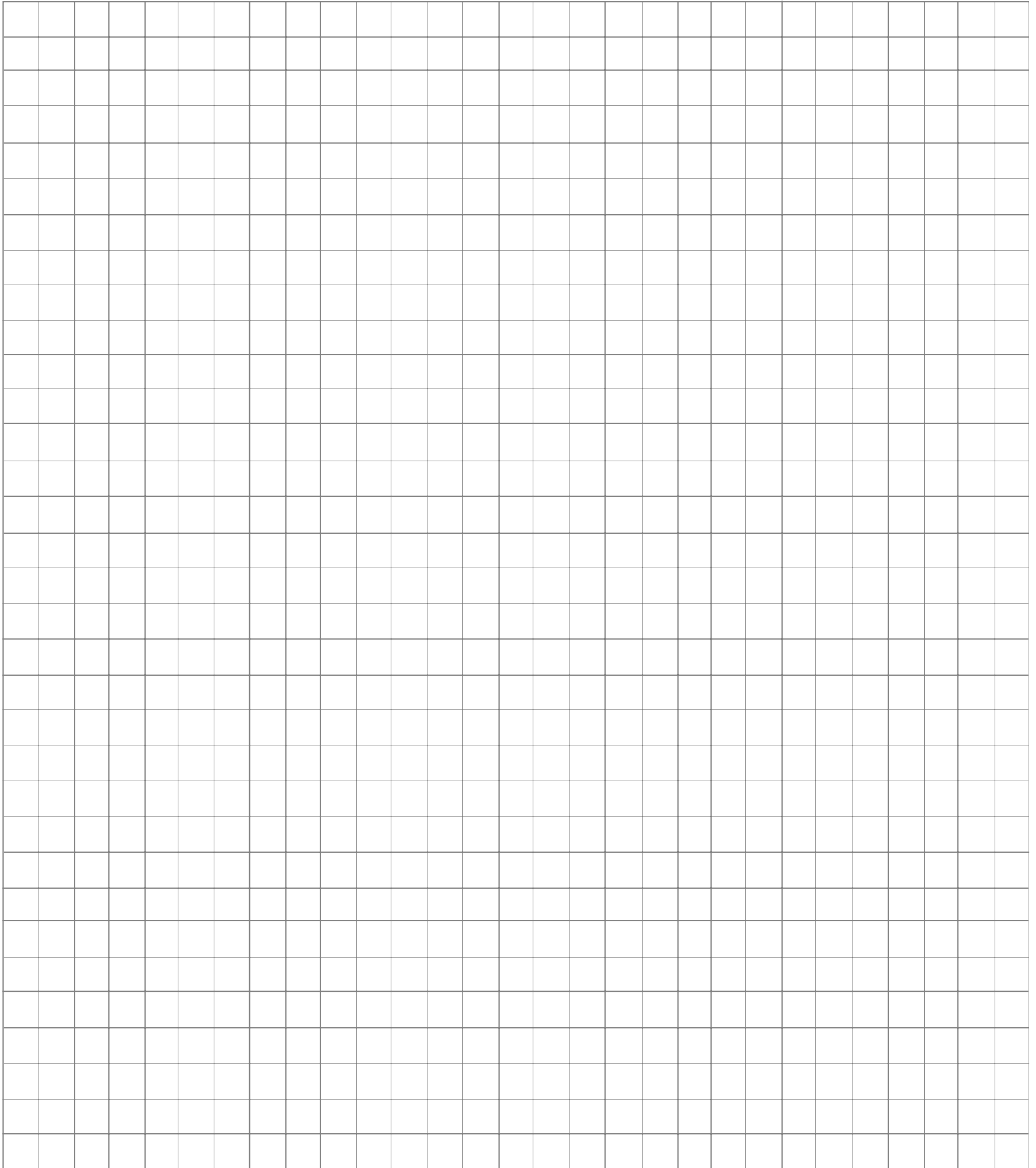

Notes:



The Heat Tracing Specialists<sup>®</sup>



**THERMON . . . The Heat Tracing Specialists®**

100 Thermon Dr. • PO Box 609 • San Marcos, TX 78667-0609  
Phone: 512-396-5801 • Facsimile: 512-754-2431 • **800-820-HEAT**  
[www.thermon.com](http://www.thermon.com)

