

Terminator DS/DE FAK-4 and FAK-4L Kit for In-Line Splice of Electrically Heated TubeTrace® Bundles INSTALLATION PROCEDURES



The Heat Tracing Specialists®

Terminator DS/DE FAK-4 and FAK-4L INSTALLATION PROCEDURES

Receiving, Storing and Handling . . .

1. Inspect materials for damage incurred during shipping.
2. Report damages to the carrier for settlement.
3. Identify parts against the packing list to ensure the proper type and quantity has been received.
4. Store in a dry location.

Terminator DS/DE FAK-4 and 4L Kit Contents . . .



Item	Qty.	Description
1	1	Expediter Assembly: Flat Mount Base, Grommet, and Grommet Compressor
2	1	Splice Cap
3	1	Splice Cover (Top)
4	1	Splice Cover (Base)
5	4	Pan Head S.S. Screws, #10-32 x .75
6	4	KEPT S.S. Nuts, #10-32
7	3	M5 Screw PN 42128
8	3	M5 Lock Washer PN 42129
9	1	Heat Reflective Tape, 1.75" Wide
10	1	Glass Fiber Tape, 2" Wide
11	1	RTV Sealant Tube

Required: Order Separately for each heater to be fabricated. Refer to SCKT Instruction, Form PN50133 for additional information.

SCKT Power and End Termination Kits (one req'd. per heater)

SCKT-1D for BSX, RSX, VSX

SCKT-2D for KSX, HTSX

SCKT-3D for FP, HPT

Kit Contents . . .



Item	Quantity	Description
1	2	Splice Connection Boots
2	1	Large Wire Nut
3	2	Medium Wire Nuts
4	2	Small Wire Nuts
5	1	RTV Tube
6	1	GRW-G Grommet (For SCKT-3D Terminator kits only)



The Heat Tracing Specialists®

Dimensions . . .

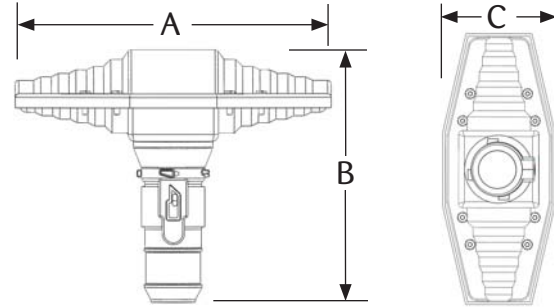

	A inch (mm)	B inch (mm)	C inch (mm)
Terminator DS/DE FAK-4	11-1/4" (210 mm)	9" (305 mm)	4-5/8" (210 mm)
Terminator DS/DE FAK-4L	14-1/2" (248 mm)	9-1/4" (305 mm)	5-1/2" (248 mm)

Installation Precautions . . .

- To minimize the potential for arcing on electrical heat tracing and fire caused by product damage or improper installation, use ground-fault protection. The National Electrical Code (NEC) and Canadian Electrical Code (CEC) require ground-fault protection of equipment for each branch circuit supplying electrical heat tracing.
- Installation must comply with Thermon requirements and be installed in accordance with the NEC, CEC, or any other applicable national and local codes.
- Component approvals and performance ratings are based on the use of Thermon specified parts only. User supplied power connection fittings must be listed or certified for intended use.
- De-energize all power sources before opening enclosure.
- Keep ends of heating cable and kit components dry before and during installation.
- Individuals installing these products are responsible for complying with all applicable safety and health guidelines. Proper personal protective equipment, or PPE, should be utilized during installation. Contact Thermon if you have any additional questions.

Terminator DS/DE Certifications/Approvals . . .



IP66 NEMA/Type 4X -60°C ≤ Ta ≤ +55°C
Ordinary & Hazardous Locations
Class I, Division 2, Groups A, B, C, & D, Zone 2 IIC
Class II, Division 2, Groups F & G,
Class III Listed Heat Tracing System 137M



Tools Required . . .

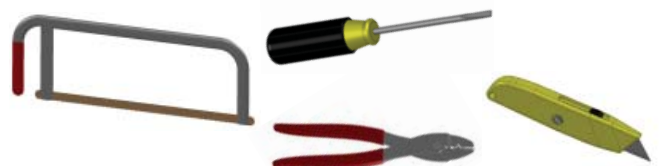

Terminator DS/DE FAK-4 and FAK-4L INSTALLATION PROCEDURES

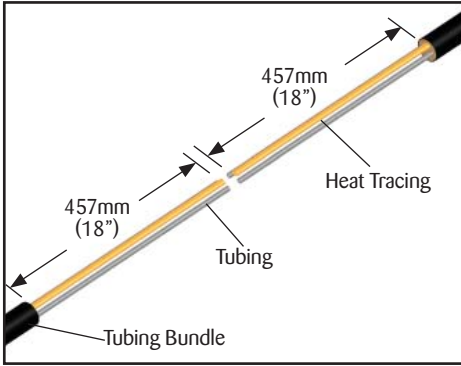

1. Remove outer jacket and insulation from tubing bundle approximately 457mm (18") from end of the tubing bundle.



Do not cut or damage the heat trace or sampling tube.

CAUTION (Found on TubeTrace SE/ME bundles)

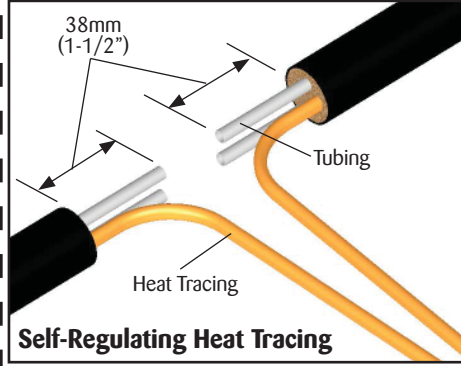

2. Trim tubing to within 38mm (1-1/2") of the end of the insulation. If self regulating heat trace proceed to step 3. For Zone-type heat trace continue with identification of bus connection on step 2a.

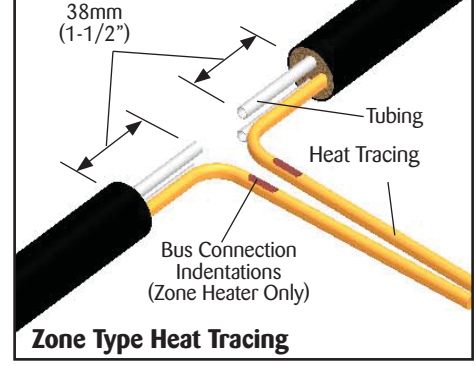

- 2a. Strip back bundle insulation 38mm (1 1/2") to 76mm(3") beyond bus connection indentation of each heat tracing. If bus connection indentation is less than 305mm (12")-381mm (15") from end of the heat tracing, proceed stripping the bundle insulation to the next indentation. Trim tubes so the bus connection indentation on each meet.

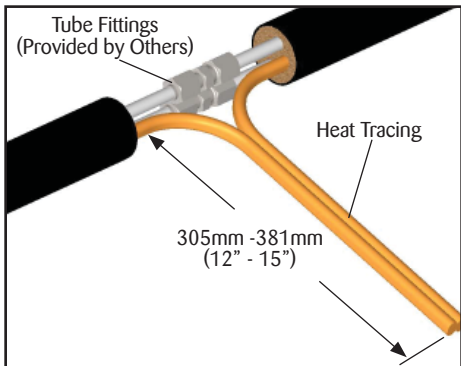

3. Make tube fitting connections with appropriate fittings (provided by others). Test fittings for leaks before proceeding.

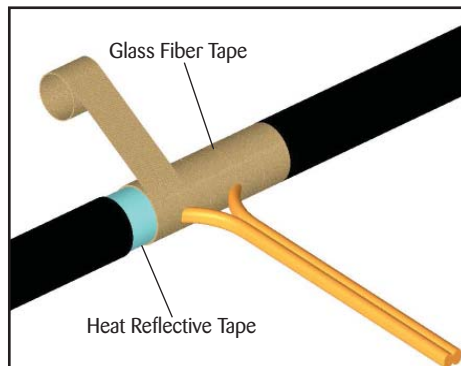

4. Wrap tube and heat trace with 1 pass of reflective tape (25% overlap), then wrap with 3 passes of glass fiber tape (50% overlap), or until fiber tape is equal to original bundle insulation thickness.

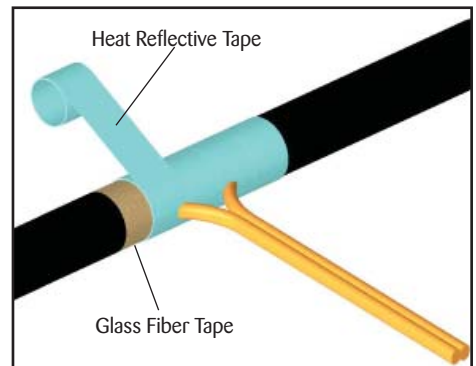

5. Complete with additional passes of heat reflective tape.

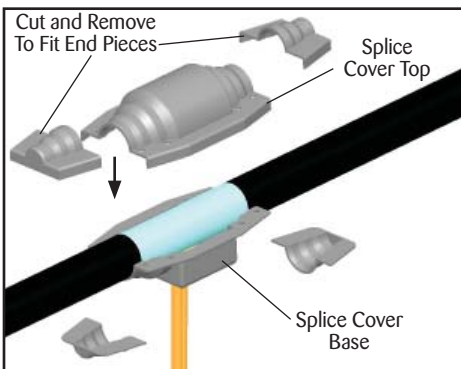

6. Cut splice cover ends to match outside diameter of tubing bundle.

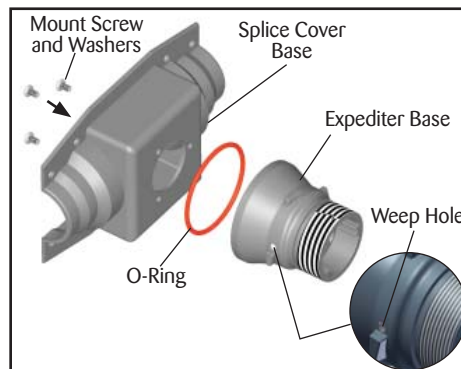

7. Mount Expediter Base with O-Ring to bottom splice cover using (3) M5 mounting screws and lock washers. Punch out weep hole

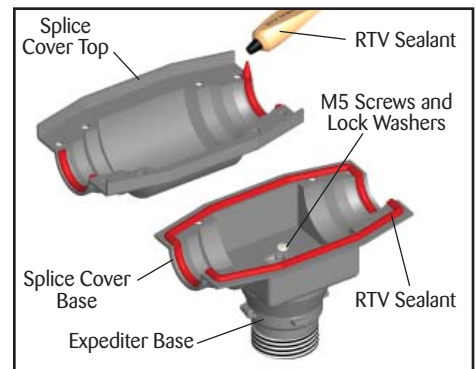

8. Form a gasket by applying RTV sealant to the splice cover base and along radius of the splice cover top as shown.

Terminator DS/DE FAK-4 and FAK-4L INSTALLATION PROCEDURES

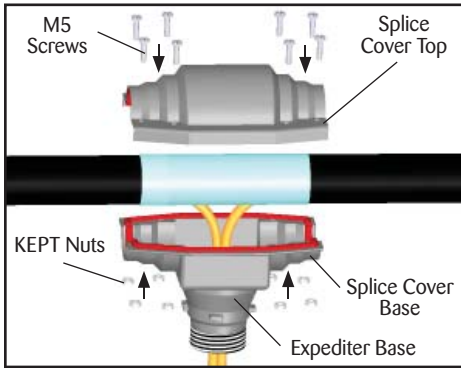

9. Assemble splice cover top, tubing bundle, and splice cover base together as shown using M5 X 3/4" pan head screws and M5 KEPT nuts.

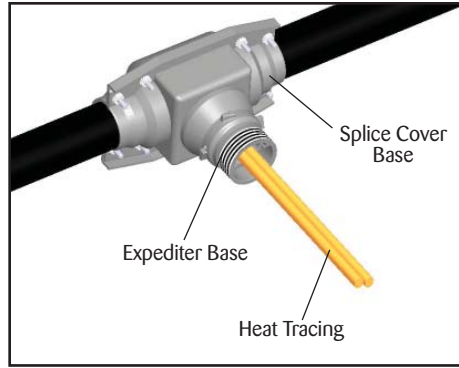

10. Assembled DS/DE FAK-4 without junction box.

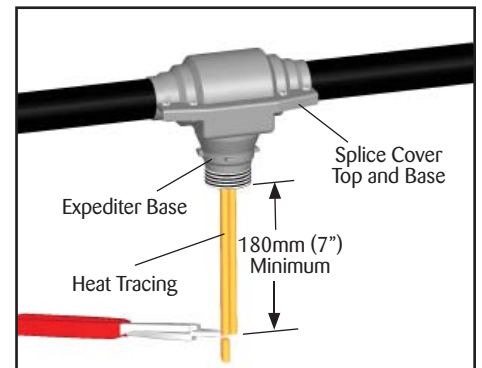

11. Trim heat tracing to 180mm (7") minimum from expediter base.

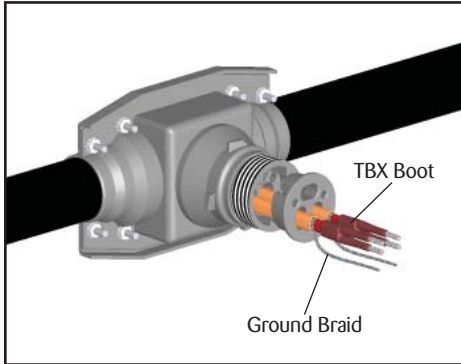

12. Terminate heat tracing with appropriate SCTK termination kit. Refer to SCTK installation instructions for details not addressed here.

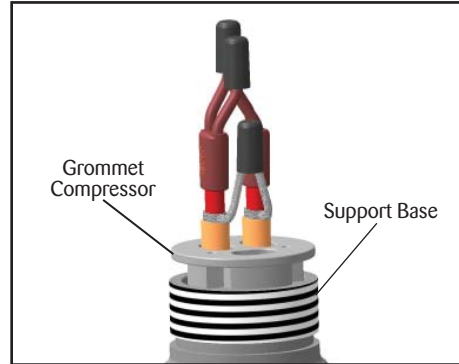

13. For splice connections: Connect bus wire using small wire nuts (for BSX, HTSX, KSX) or medium wires. (for RSX, VSX, HPT, and FP). Connect braid wire using large wire nut. See wiring details for splice connections.

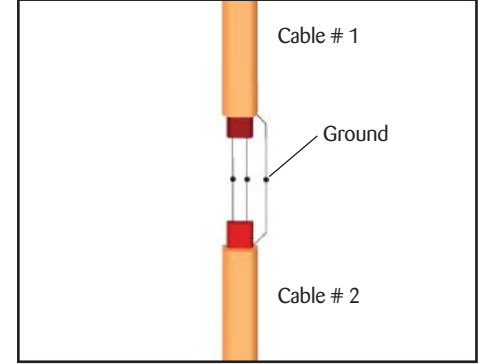

14. Complete system wiring between fabricated heat tracing.

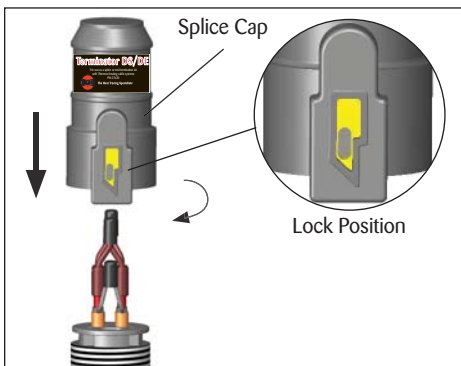

15. Mount splice cap to Terminator base and tighten securely. Make sure latch mechanism is in the locked position.

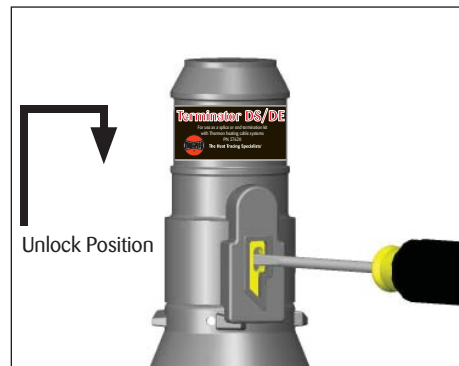

16. To remove splice cap, lift latch mechanism to unlock position (as shown) and unscrew.

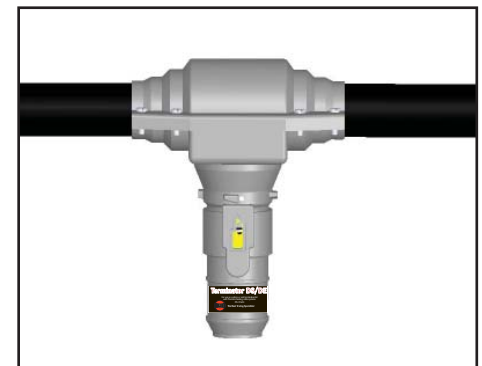

17. Tighten cap securely.



THERMON . . . The Heat Tracing Specialists®
 100 Thermon Dr. • PO Box 609 • San Marcos, TX 78667-0609
 Phone: 512-396-5801 • Facsimile: 512-396-3627
1-800-820-HEAT • In Canada call **1-800-563-8461**

For the Thermon office nearest you
 visit us at . . .
www.thermon.com

ISO 9001
 REGISTERED

Specifications and information are subject to change without notice. Form PN50062-0612