

# **HeetSheet<sup>®</sup>**

## **INSTALLATION PROCEDURES**



**The Heat Tracing Specialists<sup>®</sup>**

# HeetSheet® Vessel Heating/Cooling System

The following installation procedures are suggested guidelines for the installation of Thermon's HeetSheet system. They are not intended to preclude the use of other methods and good engineering or field construction practices.

## Receiving, Storing and Handling . . .

1. Inspect materials for damage incurred during shipping. Report damages to the carrier for settlement.
2. Shipping cartons are marked on the outside with the product description, sales order number and quantity. Compare information on shipping carton with packing slip and purchase order to verify receipt of correct shipment.
3. Product should be stored indoors away from standing water; however, if outdoor storage is required, a protective covering should be used. Moderate freezing temperatures will not damage the product. Store panel at or above 50°F (10°C) for at least four hours prior to installation to permit heat transfer compound to mold to irregularities in vessel.
4. Do not lift the HeetSheet by the inlet or outlet media connections. Use caution not to disturb the factory-applied heat transfer compound when handling panel.

## Surface Preparation/Layout . . .

1. Surface area where the HeetSheet is to be installed must be reasonably clean. Remove dirt, rust and scale with a wire brush and oil and grease film with a suitable solvent. Mill varnish and protective coatings may be removed with a suitable stripper.
2. To provide maximum heat transfer efficiency, HeetSheets are factory rolled to conform to the radius of the vessel. Compare Illustration A to the HeetSheet panels received to identify roll style configuration. This will determine the banding placement required to permanently attach the panel.

### Illustration A: Panel Roll Styles

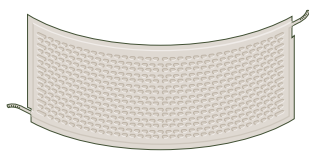

Roll Style 1

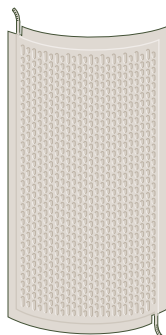

Roll Style 2



The Heat Tracing Specialists®

3. Locate panel(s) on the lower quadrant of the vessel. Typically panel should not extend above the vessel's normal minimal liquid level. Space panels evenly around circumference of vertical vessels and along lower area of horizontal vessels to avoid obstructions.

## Panel Attachment . . .

1. Remove protective polyethylene film from back of panel. The protective covering is utilized for shipping purposes only.
2. Temporarily attach panel to the vessel wall using one of the following methods:
  - A. Attach 2" (51 mm) wide fiberglass reinforced or masking tape along the edge of HeetSheet.
  - B. Wrap spring-loaded rope around the vessel.
  - C. Weld temporary support angles to the vessel wall (metal vessels only).

Refer to Illustration B for temporary panel attachment.

### Illustration B: Temporary Panel Attachment

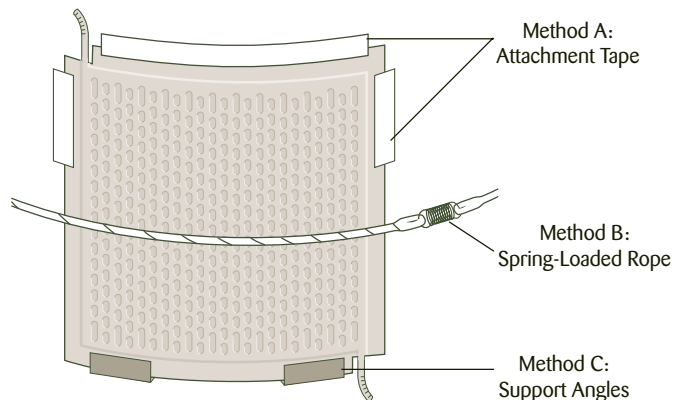

3. Permanently secure HeetSheet to the vessel wall using steel straps or stainless steel banding, crimp-type seals and a banding attachment tool.
  - Steel straps should be a minimum of 1.50" wide by 0.25" thick (38.1 mm x 6.4 mm).
  - Stainless steel banding should be a minimum of 0.50" wide by 0.030" thick (12.7 mm x 0.76 mm)\*.
  - Stainless steel banding tool should exert a force of 1,000 pounds (4,448 N) or greater.\*

\*Stainless steel banding, crimp seals and attachment tool meeting the required specifications are available from Thermon.

# INSTALLATION PROCEDURES

4. Illustration C depicts roll style 2 installation. For strap or banding requirements for roll style 1 configuration, refer to typical HS-2 banding placement.

**Illustration C: Strap/Banding Placement**

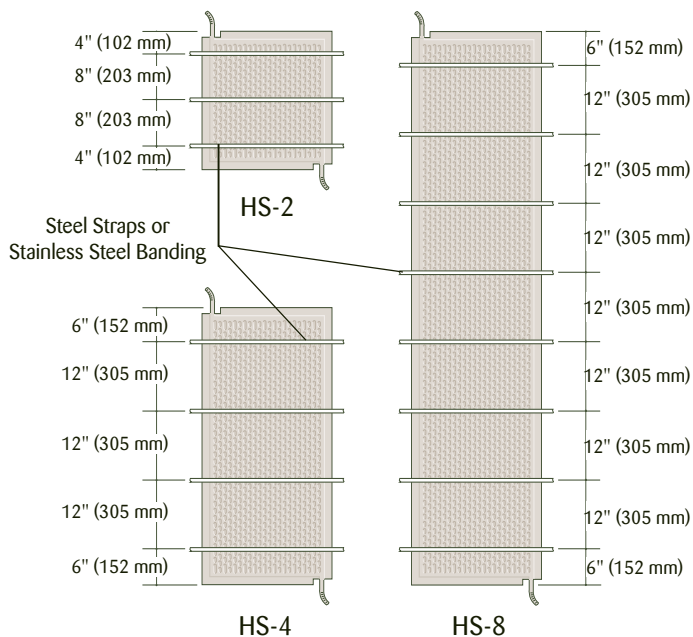

5. Banding on vessels smaller than 10' (3 m) in diameter may be installed completely around the vessel (see Illustration D).

**Illustration D: Permanent Circumferential Banding**

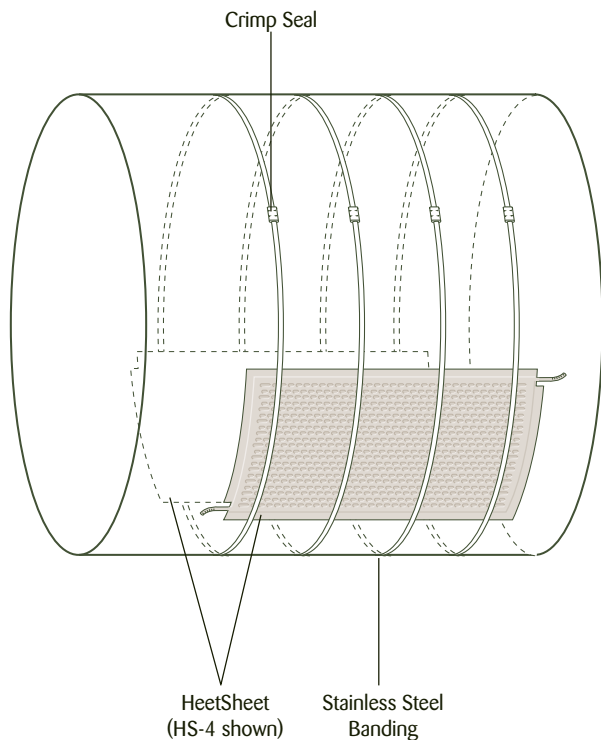

6. For vessels larger than 10' (3 m) in diameter, circumferential banding should not be used. Banding on larger vessels will stretch creating possible air gaps and reduction of heat transfer rates. Segment the banding and attach using one of the following methods:

- A. Welded stud
- B. Anchor plate

Refer to Illustration E for permanent segmental banding.

**Illustration E: Permanent Segmental Banding**

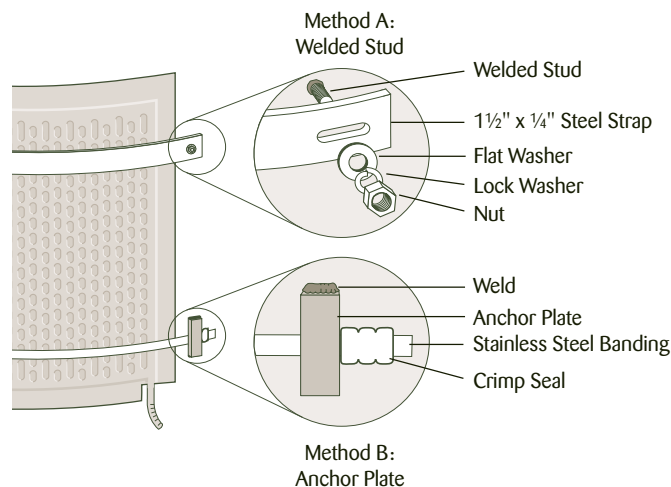

7. Installations where additional heat is required on the conical portion of the vessel may be traced with tubing in the form of hairpin loops. Secure tubing with welded studs or anchor plates as outlined in Step 6. Use heat transfer compound on tracers (see Illustration F).

**Illustration F: Conical Installation**

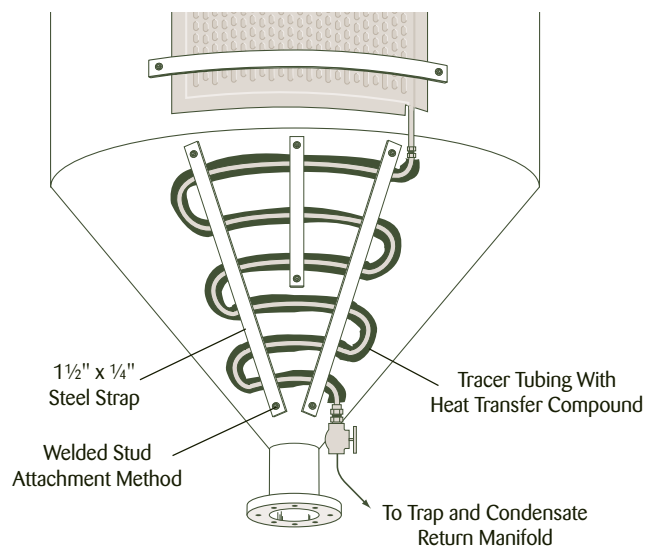

# HeetSheet® Vessel Heating/Cooling System

8. Install ThermoTube® steam supply and return tubing to collection manifolds and properly terminate all inlet and outlet media connections using an FAK-7 end seal kit. The steam supply should start at the highest point of the HeetSheet so that flow is generally downward to avoid trapping water during shutdown periods (see Illustration G). Each panel should utilize a steam trap to prevent preferential steam flow.
9. In situations where excessive moisture is expected or thermal insulation will not be installed immediately following HeetSheet installation, flashing should be installed using waterproof mastic to prevent water from accumulating behind the panel.

## Inspection of System . . .

1. Thoroughly inspect banding after installation is complete to verify proper tension.
2. After all connections to the supply header and collection manifolds have been completed, test the circuit for leaks by subjecting it to steam pressure equal to or greater than that which is to be used in the system or by suitable hydrostatic tests. Repair all leaks and retest the system.

**Illustration G: Typical HeetSheet Installation**

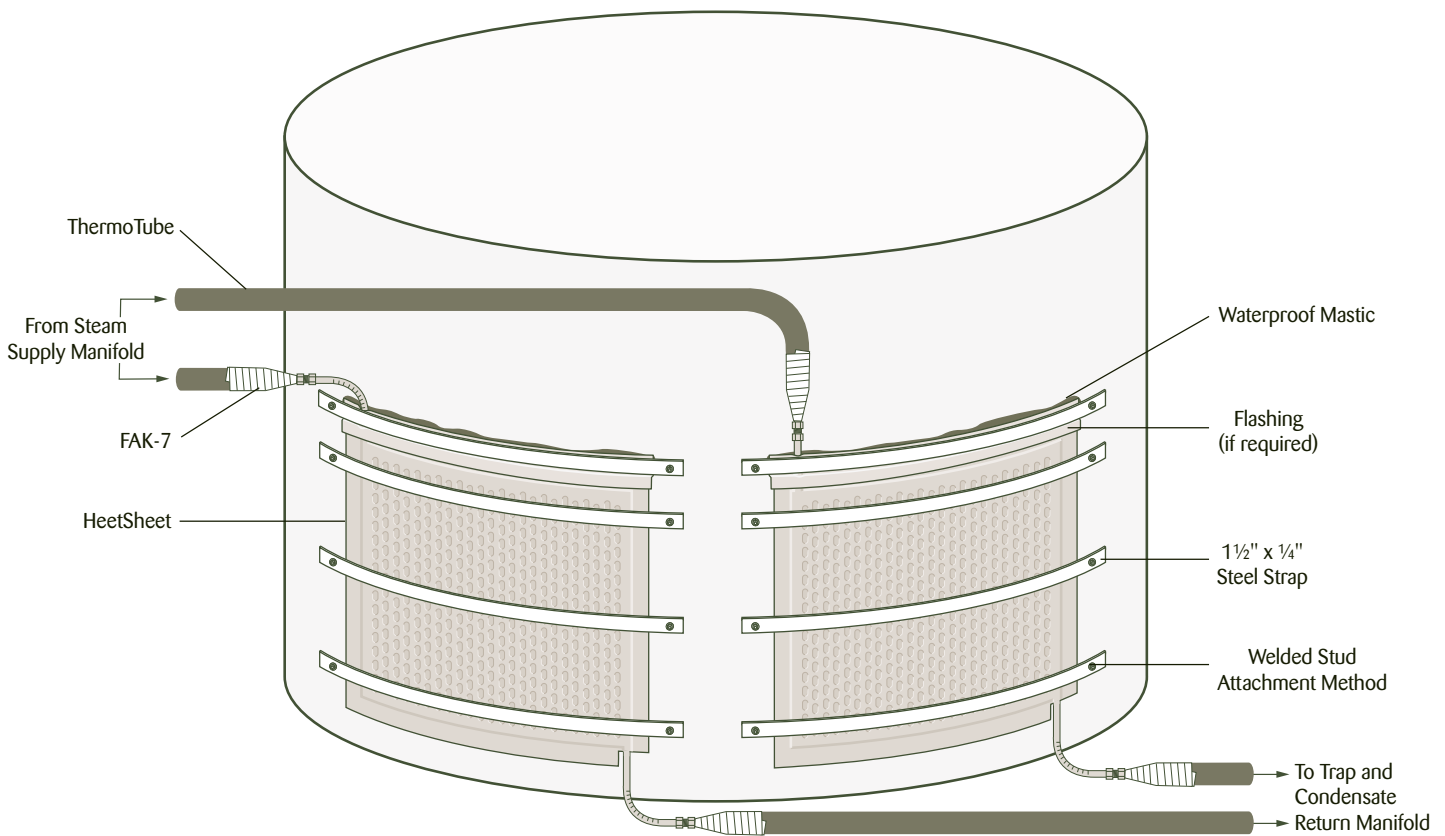

**THERMON . . . The Heat Tracing Specialists®**

100 Thermon Dr. • PO Box 609 • San Marcos, TX 78667-0609  
Phone: (512) 396-5801 • Facsimile: (512) 754-2420 • **1-800-820-HEAT**  
www.thermon.com In Canada call **1-800-563-8461**

ISO 9001  
REGISTERED