

# HMTK

Power, Splice and End Termination Kit

## INSTALLATION PROCEDURES



**The Heat Tracing Specialists®**

# HMTK

## Receiving, Storing and Handling . . .

1. Inspect materials for damage incurred during shipping.
2. Report damages to the carrier for settlement.
3. Identify parts against the packing list to ensure the proper type and quantity has been received.
4. Store in a dry location.

## Kit Contents . . .



Item	Quantity	Description
1	1	RTV Tube
2	4	PTFE Tape Strip 6"
3	1	Compression Fitting
4a	1	TBX-HMT Power/Splice Termination Grommet (HMTK-P)
4b	1	ET-HMT End Termination Grommet (HMTK-ET)
5	1	Marking Tag
6	1	Anti-Short Bushing
7	1	Cable Sleeve

## Tools Required . . .



## Installation Precautions . . .

- To minimize the potential for arcing and fire caused by product damage or improper installation use ground-fault protection. The Canadian Electrical Code (CEC) requires ground-fault protection of equipment for each branch circuit supplying electric heat tracing.
- Installation must comply with Thermon requirements and be installed in accordance with the CEC or any other applicable national and local codes.
- Component approvals and performance ratings are based on the use of Thermon specified parts only.
- De-energize all power sources before opening enclosure.
- Keep ends of heating cable and kit components dry before and during installation.
- Individuals installing these products are responsible for complying with all applicable safety and health guidelines. Proper Personal Protective Equipment (PPE) should be utilized during installation. Contact Thermon if you have any additional questions.
- The HMTK Power and End Termination kits are intended to be mounted off of the heated surface.
- The metal covering shall not be used as the bonding-to-ground means. Alternate means of protection shall be provided per applicable codes. The metal covering on this set and metal structures or materials used for the support of this set shall be grounded.

## HMTK Certifications/Approvals<sup>1</sup> . . .

 Class I, Div. 2, Groups A, B, C, D  
 Class II, Div. 2, Groups E, F, G  
 Class III  
 Ex e II

### Note:

1. These sets have been evaluated as components of Thermon's CSA Approved connection kits, such that the area use ratings depend on the rating of the connection kits.



The Heat Tracing Specialists®

# HMTK

# INSTALLATION PROCEDURES



**1.** Cut HMT cable to the desired length. Allow an extra 24" (610mm) for 1' (305mm) zoned cable and 48" (1219mm) for 2' (610mm) zoned cable for each end as well as the appropriate length for any valves, flanges or pipe supports. Slide the cable sleeve over the metal sheath.

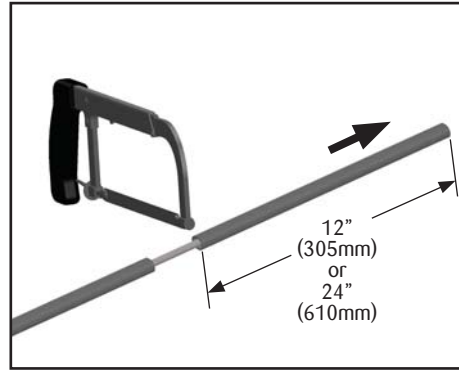

**2.** Using a hacksaw, cut the sheath back 12" (305mm) for 1' (305mm) zoned cable or 24" (610mm) for 2' (610mm) zoned cable from the connecting end being careful to not cut or damage the heating core. Remove and discard the sheath.

**!** Do not damage internal components

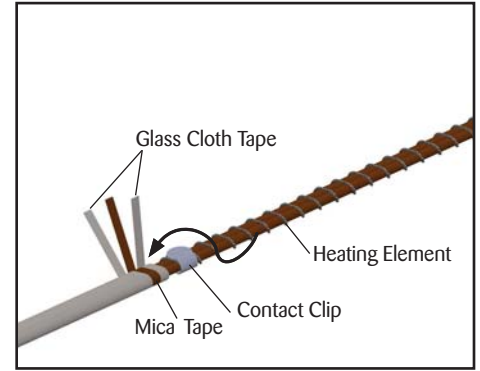

**3.** Unwrap the outer layers of glass cloth tape and mica insulating tape to expose the contact clip holding the heating element in contact with the bus wire. Cut and remove the unwrapped glass tape and mica wrap.

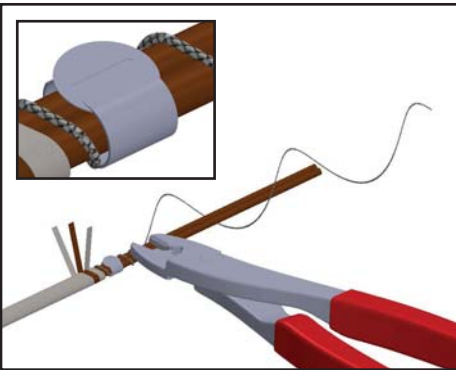

**4.** Unwind the heating element to the contact clip. Cut and discard heating element.

**!** Do not cut bus wire insulation or bus wires.

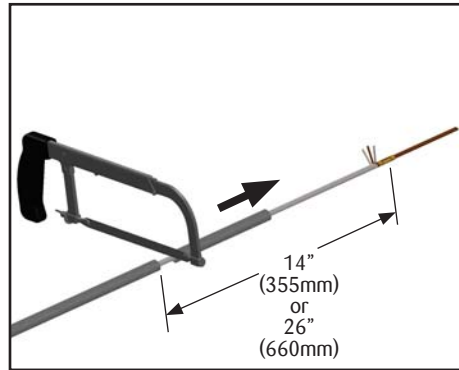

**5.** Measure 14" (355mm) for 1' (305mm) zoned cable or 24" (660mm) for 2' (610mm) zoned cable from the center of the exposed clip, mark the sheath and cut around using the hacksaw being careful to not cut or damage the heating core. Dispose of the removed sheath.

**!** Do not damage internal components

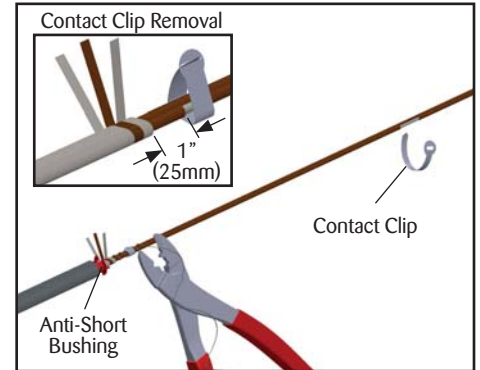

**6.** Install the anti-short bushing between the core and the metal sheath. Remove the first contact clip. Unwind and remove the glass tape and mica layers (as in Step 3) 1" (25mm) past second notch. Unwind the heating element to the contact clip. Cut and discard heating element.

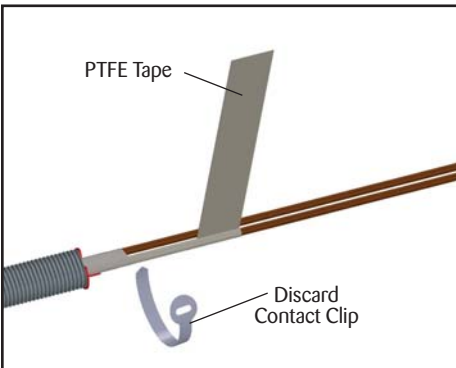

**7.** Remove the second contact clip and cut heating element back to glass tape. Apply a 6" (152mm) piece of PTFE tape around the fiberglass tape and heating element to prevent unwrapping. For power connections (HMTK-P), wrap the exposed bus wire area located at the second contact clip location with two (2) 6" (152mm) pieces of PTFE tape to eliminate possibility of contact between the cable sheath and the bus wire. Start 1" (25mm) behind the notch using a 50% overlap pattern.

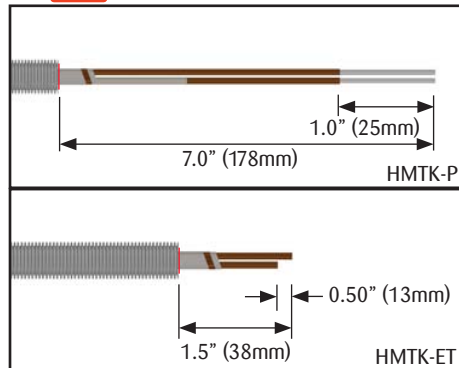

**8.** For power connections (HMTK-P), measure 7.0" (178mm) from the end of the metal sheath and trim bus wires. Remove the 1" (25mm) of bus wire insulation from the ends of each wire.

For end terminations (HMTK-ET), measure 1.5" (38mm) from the end of the metal sheath and trim the bus wires. Stagger cut one of the bus wires 0.50" (13mm). Tape bus wires individually and then together using PTFE tape strips.

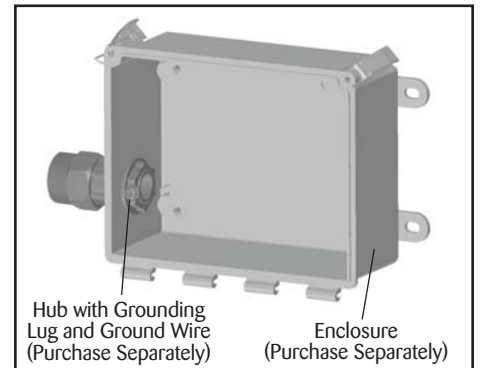

**9.** Wrap the NPT threads of the HMTK connection kit with PTFE tape and screw the body of the HMTK connection kit into an enclosure (purchase separately) certified for the application with a minimum IP66/Type 4 rating. When using a non-metallic junction box, a hub with grounding lug (purchase separately) must be used.

# HMTK

## HMTK-P (Power and Splice Connection Kit)

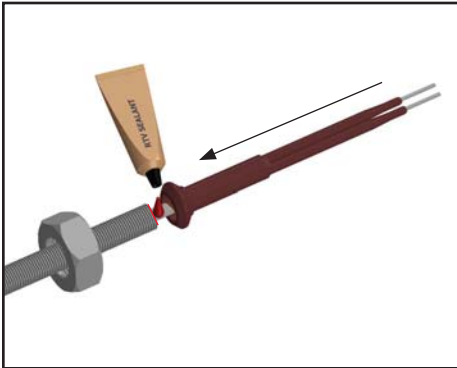

**10a.** Slide the compression nut onto the cable. Next, apply a liberal amount of RTV sealant to the inside of the grommet and the conductors and slide over the conductors and over the metallic sheath.

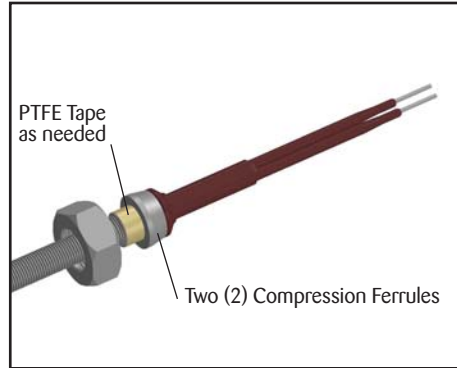

**11a.** Install the two halves of the compression ferrules so that they are touching the back side of the grommet. A piece of PTFE tape may be useful to hold these ferrules in place.

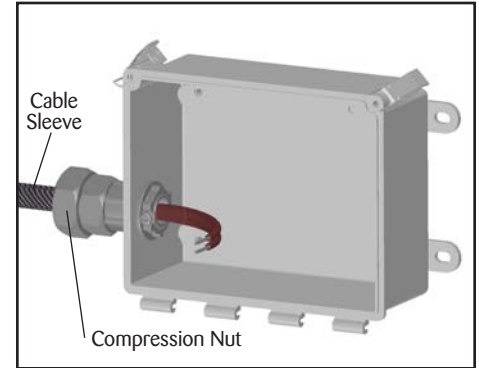

**12a.** Insert the cable through the fitting and tighten the compression nut, until it makes positive contact with the compression ferrule and cannot be moved by hand. Then tighten fitting additional 1/4 turn. Slide the cable sleeve up to the compression ferrule.

## HMTK-ET (End Termination Kit)

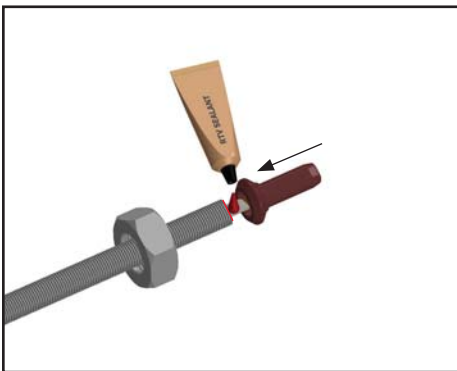

**10b.** Slide the compression nut onto the cable. Next, apply a liberal amount of RTV sealant to the inside of the grommet and the conductors and slide over the conductors and over the metallic sheath.

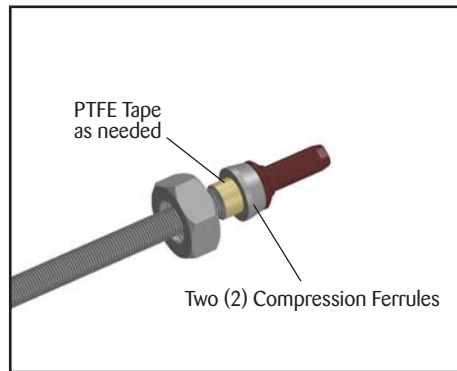

**11b.** Install the two halves of the compression ferrules so that they are touching the back side of the grommet. A piece of PTFE tape may be useful to hold these ferrules in place.

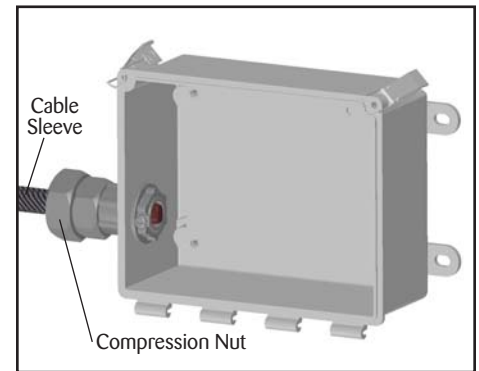

**12b.** Insert the cable through the fitting and tighten the compression nut, until it makes positive contact with the compression ferrule and cannot be moved by hand. Then tighten fitting additional 1/4 turn. Slide the cable sleeve up to the compression ferrule.

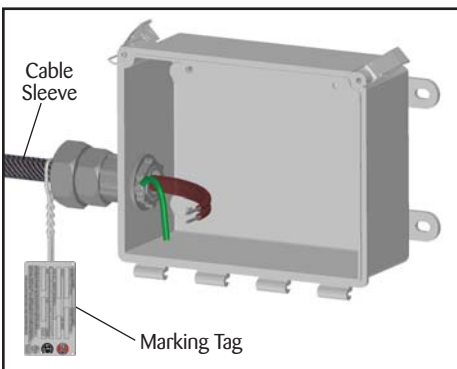

**13.** Secure marking tag with stainless tie wire within 3" (76mm) of the power connection.



ISO 9001  
REGISTERED

**THERMON . . . The Heat Tracing Specialists®**

100 Thermon Dr. • PO Box 609 • San Marcos, TX 78667-0609

Phone: 512-396-5801 • Facsimile: 512-396-3627 • **1-800-820-HEAT**

www.thermon.com

In Canada call **1-800-563-8461**

Specifications and information are subject to change without notice. Form TMP0034-1011

For the Thermon office nearest you  
visit us at . . .

[www.thermon.com](http://www.thermon.com)